

TaiShan 200 Server (Model 5280 V2)

Technical White Paper

Issue **02**
Date **2026-05-28**



Copyright © Huawei Technologies Co., Ltd. 2026. All rights reserved.

No part of this document may be reproduced or transmitted in any form or by any means without prior written consent of Huawei Technologies Co., Ltd.

Trademarks and Permissions



HUAWEI and other Huawei trademarks are trademarks of Huawei Technologies Co., Ltd.

All other trademarks and trade names mentioned in this document are the property of their respective holders.

Notice

The purchased products, services and features are stipulated by the contract made between Huawei and the customer. All or part of the products, services and features described in this document may not be within the purchase scope or the usage scope. Unless otherwise specified in the contract, all statements, information, and recommendations in this document are provided "AS IS" without warranties, guarantees or representations of any kind, either express or implied.

The information in this document is subject to change without notice. Every effort has been made in the preparation of this document to ensure accuracy of the contents, but all statements, information, and recommendations in this document do not constitute a warranty of any kind, express or implied.

Huawei Technologies Co., Ltd.

Address: Huawei Industrial Base
Bantian, Longgang
Shenzhen 518129
People's Republic of China

Website: <https://e.huawei.com>

Security Declaration

Product Lifecycle

Huawei's regulations on product lifecycle are subject to the *Product End of Life Policy*. For details about this policy, visit the following web page:

<https://support.huawei.com/ecolumnsweb/en/warranty-policy>

Vulnerability

Huawei's regulations on product vulnerability management are subject to the *Vul. Response Process*. For details about this process, visit the following web page:

<https://www.huawei.com/en/psirt/vul-response-process>

For vulnerability information, enterprise customers can visit the following web page:

<https://securitybulletin.huawei.com/enterprise/en/security-advisory>

Initial Digital Certificate

The Initial digital certificates on Huawei devices are subject to the *Rights and Responsibilities of Initial Digital Certificates on Huawei Devices*. For details about this document, visit the following web page:

<https://support.huawei.com/enterprise/en/bulletins-service/ENEWS2000015789>

Huawei Enterprise End User License Agreement

This agreement is the end user license agreement between you (an individual, company, or any other entity) and Huawei for the use of the Huawei Software. Your use of the Huawei Software will be deemed as your acceptance of the terms mentioned in this agreement. For details about this agreement, visit the following web page:

<https://e.huawei.com/en/about/eula>

Lifecycle of Product Documentation

Huawei after-sales user documentation is subject to the *Product Documentation Lifecycle Policy*. For details about this policy, visit the following web page:

<https://support.huawei.com/enterprise/en/bulletins-website/ENEWS2000017761>

About This Document

Purpose

This document describes the appearance, performance parameters, and component compatibility of the TaiShan 200 server (model 5280 V2).





Intended Audience

The document is intended for:

- Huawei presales engineers
- Presales engineers of channel partners
- Enterprise presales engineers

Symbol Conventions

Symbols that may be found in this document are defined as follows.

Symbol	Description
 DANGER	Indicates a hazard with a high level of risk which, if not avoided, will result in death or serious injury.
 WARNING	Indicates a hazard with a medium level of risk which, if not avoided, may result in death or serious injury.
 CAUTION	Indicates a hazard with a low level of risk which, if not avoided, may result in minor or moderate injury.
 NOTICE	Indicates a warning about equipment or environment safety. If not avoided, it may result in equipment damage, data loss, performance deterioration, or other unanticipated results. NOTICE is used to address practices not related to personal injury.
 NOTE	Supplements the important information in the main text. NOTE is used to address information not related to personal injury, equipment damage, and environment deterioration.

Change History

Issue	Release Date	Change Description
02	2026-05-28	<ul style="list-style-type: none">• Changed the number of cores per processor to 24 or more. For details, see 2 Product Feature and 6.1 Technical Specifications.• Added support for 2 x 2.5-inch SAS/SATA drives in I/O module 2. For details, see 5.6.1 Drive Configurations.
01	2025-10-17	This issue is the first official release.

Contents

About This Document	iii
1 Introduction	1
2 Product Feature	2
3 Physical Structure	4
4 Logical Structure	7
5 Hardware	9
5.1 Front Panel.....	9
5.2 Rear Panel.....	12
5.3 Basic Computing Unit.....	15
5.3.1 Introduction to Ports on the Basic Board.....	15
5.3.2 Memory.....	16
5.3.2.1 DIMM Slot Numbers.....	16
5.3.2.2 DIMM Installation Rules.....	18
5.3.2.3 DIMM Specifications.....	19
5.3.2.4 Memory Protection.....	20
5.4 System Extension Unit.....	20
5.5 Heat Dissipation Components.....	21
5.5.1 Fan Board.....	22
5.5.2 Fan Module.....	22
5.6 Storage Components.....	23
5.6.1 Drive Configurations.....	23
5.6.2 Drive Numbers.....	24
5.6.3 Drive Indicators.....	26
5.6.4 Rear Drive Modules.....	28
5.6.5 RAID Levels.....	29
5.7 Storage Extension Components.....	30
5.8 I/O Extension Components.....	33
5.9 FlexIO Cards.....	45
5.10 BMC Card.....	46
6 Product Specifications	48

6.1 Technical Specifications	48
6.2 Environmental Specifications	50
6.3 Physical Specifications	52
6.4 PSU Specifications	53
7 Compatibility	55
7.1 Hardware and Software Compatibility	55
7.2 I/O Extension	55
8 System Management	56
9 Certifications	58

1 Introduction

The TaiShan 200 server powered by Huawei Kunpeng 920 processors is dedicated for data centers. The TaiShan 200 server (model 5280 V2) storage model (marked as K42R-02 on the nameplate) is a 4U rack server. It features high-performance computing, large-capacity storage, low power consumption, easy management, and easy deployment, and is ideal for storage services.

Figure 1-1 Appearance



2 Product Feature

Performance and Scalability

- This product supports server-oriented 64-bit high-performance Kunpeng 920 multicore processors, which integrate DDR, PCIe 5.0, 100GE, 25GE, 10GE, and GE ports to provide comprehensive system-on-chip (SoC) functions.
- Each server supports two processors (≥ 24 cores per processor), maximizing the concurrent execution of multithreaded applications.
- Flexible drive configurations satisfy a variety of business requirements and ensure high elasticity and scalability of storage resources.
- FlexIO cards provide multiple Ethernet ports.
- Up to 8 standard PCIe slots are allowed.

NOTE

The actual configurations are subject to the configuration manual.

Availability and Serviceability

- This server supports SAS/SATA/NVMe drives. SAS/SATA drives can provide RAID cache, and RAID levels of SAS/SATA drives can be set based on the RAID controller card type. For details, see [RAID Controller Card User Guide \(Arm\)](#). It supports a supercapacitor for power failure protection and hot swap of non-system drives.
- The UID and HLY indicators on the panel and the Intelligent Baseboard Management Controller (iBMC) WebUI help technical support personnel promptly obtain the status of key components and locate failed or failing components. This simplifies maintenance, accelerates troubleshooting, and improves system availability.
- iBMC continuously monitors system parameters and triggers alarms to minimize system downtime.

Manageability and Security

- The iBMC monitors system running status and provides remote management.
- The integrated industry-standard unified extensible firmware interface (UEFI) increases efficiency of setup, configuration, and update, and simplifies fault handling.

Energy Efficiency

- The server supports platinum power supply units (PSUs), which provide 94% power efficiency at 50% load.

- The voltage regulator-down (VRD) PSUs reduce the energy loss in DC-DC power conversion.
- The server supports active and standby PSUs.
- The server supports proportional-integral-derivative (PID) intelligent fan speed adjustment, which reduces power consumption.
- The improved thermal design with energy-efficient fan modules ensures optimal heat dissipation and reduces overall system power consumption.
- Drives can be powered on at different times to reduce startup power consumption.
- The server supports SSDs. SSDs consume 80% less power than HDDs.

3 Physical Structure

The server provides 32 DIMM slots. Figure 3-1 shows the components of the server.

 **NOTE**

The configurations of the server delivered to your site may vary with the configurations described in this document. This figure is for reference only and helps you understand the relative positions and names of components.

Figure 3-1 Components

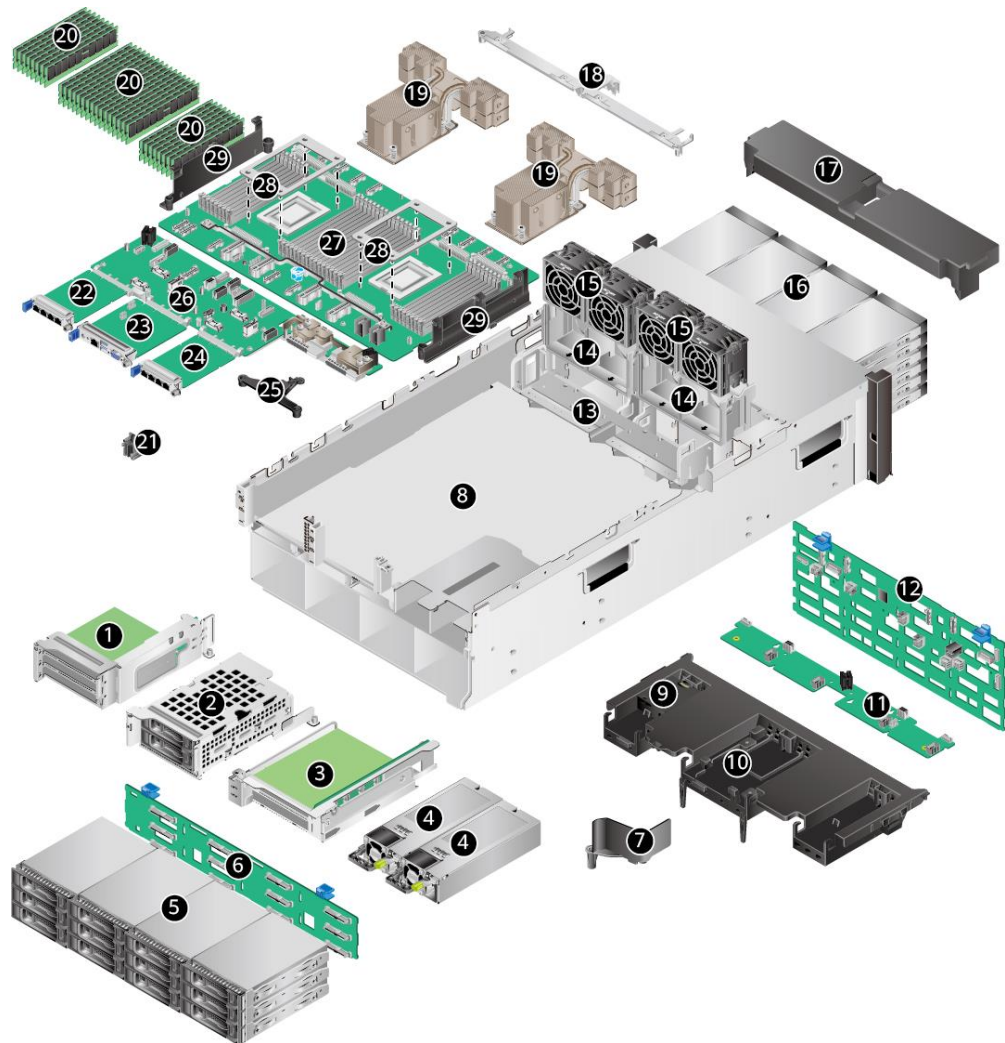

- | | | | |
|----|--|----|----------------------------------|
| 1 | I/O module 1 | 2 | I/O module 2 |
| 3 | I/O module 3 | 4 | PSUs |
| 5 | Rear drive | 6 | Rear drive backplane |
| 7 | PSU air duct | 8 | Chassis |
| 9 | Supercapacitor | 10 | Air duct |
| 11 | Fan board | 12 | Front drive backplane |
| 13 | Fan support | 14 | Fan module bracket |
| 15 | Fan modules (numbered 4, 3, 2, and 1 from upper left to lower right in the figure) | 16 | Front drive |
| 17 | Air baffle | 18 | Remote support for the heat sink |
| 19 | Heat sink | 20 | DIMM |
| 21 | Intrusion sensor | 22 | FlexIO card 1 |

23	BMC card	24	FlexIO card 2
25	OCP air duct	26	Extension board
27	Basic board	28	CPU tray
29	Cable organizer	-	-

 **NOTE**

- This figure is for reference only.
- CPUs are integrated on the basic board and cannot be replaced separately.
- For details about the spare parts, use [Spare Parts Query](#).
- The actual configurations are subject to the configuration manual.

4 Logical Structure

This product supports the Hi1711 BMC card and provides a video graphics array (VGA) port, management network port, serial port, and USB Type-C port.

Figure 4-1 shows the logical structure.

Figure 4-1 Logical structure

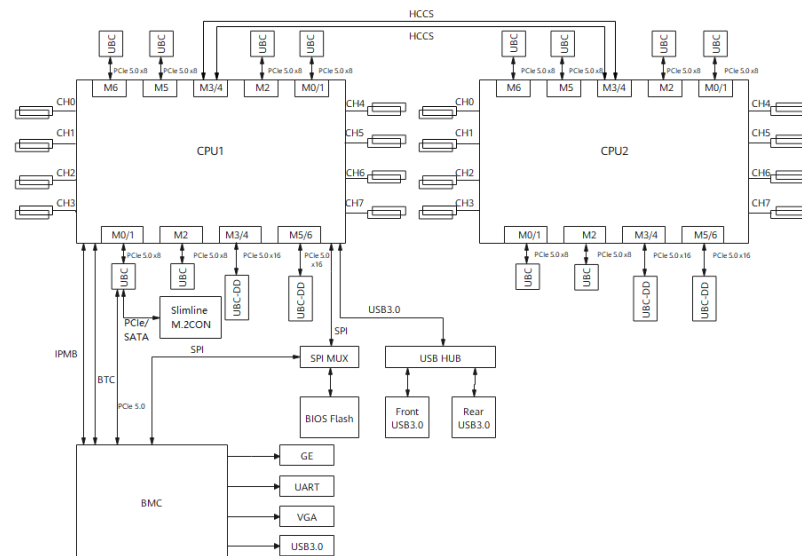

- The server uses two Huawei-developed Kunpeng 920 processors, each supporting 16 DDR DIMMs.
- The two processors interconnect with each other over two HCCS buses at a rate of up to 30 Gbit/s.
- The PCIe resources of the processors are connected to the PCIe riser card through the PCB or cables.
- The Ethernet FlexIO cards can have 4 x GE or 2 x 25GE ports.

- The independent baseboard management controller (BMC) chip supports external VGA, management, and serial ports.

5 Hardware

- 5.1 Front Panel
- 5.2 Rear Panel
- 5.3 Basic Computing Unit
- 5.4 System Extension Unit
- 5.5 Heat Dissipation Components
- 5.6 Storage Components
- 5.7 Storage Extension Components
- 5.8 I/O Extension Components
- 5.9 FlexIO Cards
- 5.10 BMC Card

5.1 Front Panel

NOTE

The actual configurations are subject to the configuration manual.

Figure 5-1 shows the components on the front panel of a server equipped with 36 x 3.5-inch drives.

Figure 5-1 Components on the front panel of a server equipped with 36 x 3.5-inch drives

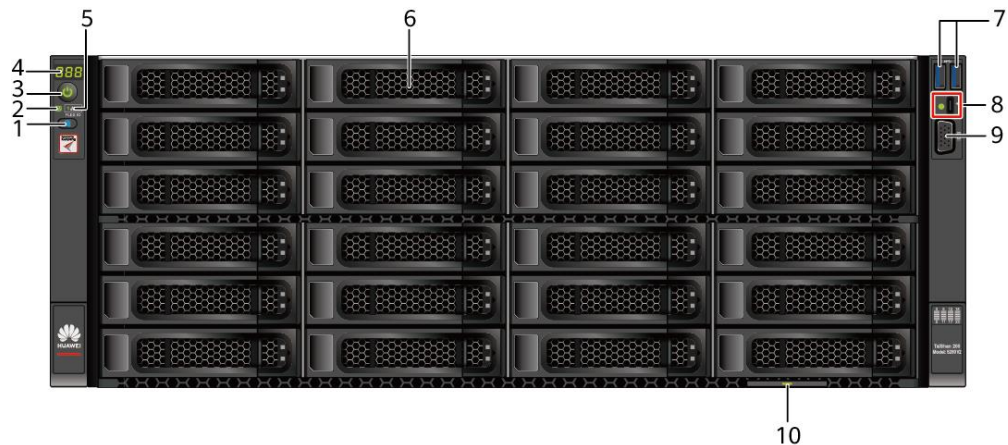

1	UID button/indicator	2	Health indicator
3	Power button/indicator	4	Fault diagnosis LED
5	FlexIO card presence indicators (1 and 2)	6	Drive/Indicator
7	USB 3.0 port	8	USB Type-C port/indicator
9	VGA port	10	Label (with the SN label)

Table 5-1 Front panel description

Name	Type	Description
USB 3.0 port	USB 3.0	Connected to a USB device. NOTE <ul style="list-style-type: none"> Before connecting a USB device, check that the USB device functions properly. The server may operate improperly if an abnormal USB device is connected. A maximum of 1 m extension cable can be used for a USB device. If USB devices, including USB flash drives and portable drives, are not detected, contact Huawei technical support.
VGA port	DB15	Connected to a terminal, such as a monitor or physical keyboard, video, or mouse (KVM). NOTE <ul style="list-style-type: none"> The VGA port on the front panel does not have cable screws, meaning the VGA cable may disconnect easily. You are advised to use the VGA port on the rear panel. The VGA port on the front panel cannot be used together with the USB Type-C port.
USB Type-C port/indicator	Type-C	Local maintenance and management port of the BMC. NOTE The USB Type-C port cannot be used together with the

Name	Type	Description
		VGA port on the front panel.
Fault diagnosis LED	-	<ul style="list-style-type: none"> • ---: The server is operating properly. • Error code: A server component is faulty. For details about error codes, see iBMC Alarm Handling .
Power button/indicator	-	Power indicator description: <ul style="list-style-type: none"> • Steady yellow: The server is in the standby state. • Steady green: The server is powered on. • Blinking yellow: The iBMC is being started. • Off: The server is not powered on. Power button description: <ul style="list-style-type: none"> • When the server is powered on, you can press this button to shut down the OS. • When the server is powered on, holding down this button for 6 seconds will forcibly power off the server. • When the server is in standby state, you can press this button to power on the server.
UID button/indicator	-	The UID button/indicator helps locate a server. UID indicator description: <ul style="list-style-type: none"> • Off: The server is not being located. • Blinking blue (for 255 seconds): The server is being located and is differentiated from other servers that are also being located. • Steady blue: The server is being located. NOTE <ul style="list-style-type: none"> • After the iBMC is initialized, the UID indicator restores to the default off state. You can press the UID button to relocate the server. • The blinking continues for 255 seconds for each setting on the iBMC. After 255 seconds, the indicator is off. UID button description: <ul style="list-style-type: none"> • You can set the UID indicator status by pressing the UID button on the panel or using the iBMC CLI or WebUI. • You can press this button to turn on or off the UID indicator. • You can hold down this button for 5 seconds to reset the iBMC.
Health indicator	-	<ul style="list-style-type: none"> • Steady green: The server is operating properly. • Blinking red at 1 Hz: A major alarm has been generated on the server. • Blinking red at 5 Hz: A critical alarm has been

Name	Type	Description
		generated on the server.
FlexIO card presence indicators (1 and 2)	-	<ul style="list-style-type: none"> • 1 and 2: 1 indicates FlexIO card 1, and 2 indicates FlexIO card 2. • Steady green: The FlexIO card is installed and identified. • Off: The FlexIO card is not installed or is faulty.
Drive/Indicator	-	For details, see 5.6.3 Drive Indicators.

5.2 Rear Panel

NOTE

The actual configurations are subject to the configuration manual.

Figure 5-2 shows the components on the rear panel of a server.

Figure 5-2 Components on the rear panel

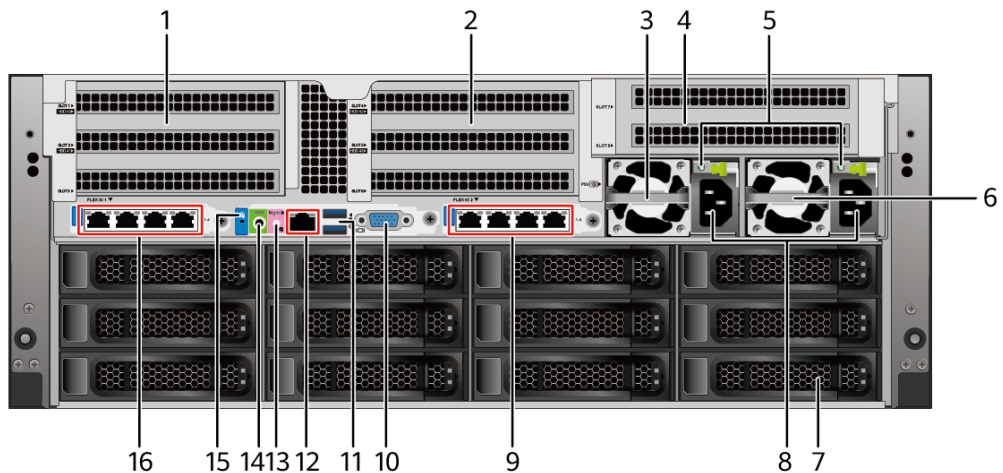

- | | | | |
|----|--|----|--|
| 1 | I/O module 1 | 2 | I/O module 2 |
| 3 | PSU 1 | 4 | I/O module 3 |
| 5 | PSU indicator | 6 | PSU 2 |
| 7 | Drive and indicator | 8 | PSU socket |
| 9 | FlexIO card 2 and its indicators
(connected to CPU 2) | 10 | VGA port |
| 11 | USB 3.0 port | 12 | Management network port and
indicator |
| 13 | UID button | 14 | Serial port |

15 UID indicator

16 FlexIO card 1 and its indicators
 (connected to CPU 1)

 **NOTE**

- The ports or indicators numbered 10 to 15 are on the BMC card.
- FlexIO cards 1 and 2 and the BMC card are not hot-swappable. If you need to replace them, power off the server first.

Table 5-2 Rear panel description

Name	Type	Quantity	Description
I/O module	-	-	I/O modules 1, 2, and 3 support riser or drive modules. <ul style="list-style-type: none"> • For details about the supported riser modules, see 5.8 I/O Extension Components. • For details about the supported drive modules, see 5.6.4 Rear Drive Modules.
VGA port	DB15	1	Connected to a terminal, such as a monitor or physical KVM.
USB 3.0 port	USB 3.0	2	Connected to a USB device. <p>NOTE</p> <ul style="list-style-type: none"> • Before connecting a USB device, check that the USB device functions properly. The server may operate improperly if an abnormal USB device is connected. • A maximum of 1 m extension cable can be used for a USB device. • If USB devices, including USB flash drives and portable drives, are not detected, contact Huawei technical support.
Management network port/indicator	RJ45	1	Management network port description: Provides a 1000 Mbit/s Ethernet port that supports 10/100/1000 Mbit/s auto-negotiation. You can manage the server through this port. <p>Management indicator description:</p> <ul style="list-style-type: none"> • Data transmission status indicator (in the upper left corner) <ul style="list-style-type: none"> – Blinking yellow: Data is being transmitted. – Off: No data is being transmitted. • Connection status indicator (in the upper right corner) <ul style="list-style-type: none"> – Steady green: The network

Name	Type	Quantity	Description
			connection is normal. – Off: The network is disconnected.
Serial port	3.5 mm	1	The serial port is used as the system serial port by default. You can set it as the iBMC serial port using CLI commands. It is used mainly for debugging.
FlexIO card/indicator	<ul style="list-style-type: none"> SF221Q NIC: RJ45 and SFP+ SF223D-H network port: SFP28 	2	Both FlexIO cards 1 and 2 can be configured with the SF221Q NIC or SF223D-H NIC. This figure is for reference only. For details about FlexIO cards, see 5.9 FlexIO Cards.
PSU socket/indicator	-	1/2	PSU socket description: <ul style="list-style-type: none"> Determine the number of PSUs based on actual requirements, and ensure that the rated power of the PSUs is greater than that of the server. You are advised to configure two PSUs to ensure reliable server operating. When only one PSU is used, do not set Predicted PSU Status or Power Supply Settings to Active/Standby on the iBMC WebUI. PSU indicator description: <ul style="list-style-type: none"> Steady green: The power input and output are normal. Steady orange: The power input is normal, but the power output fails due to overheat/overcurrent/overvoltage protection, short circuit protection, or a component failure. Blinking green at 1 Hz: <ul style="list-style-type: none"> The input is normal and the server is in the standby state. The input is overvoltage or undervoltage. For details, see TaiShan Servers Troubleshooting. Blinking green at 4 Hz: The PSU firmware is being upgraded online. Off: There is no power input.
UID indicator/button	-	-	The UID indicator/button on the rear panel has the same function as that on the front panel. For details, see Table 5-1.
Drive and	-	-	For details, see 5.6.3 Drive Indicators.

Name	Type	Quantity	Description
indicator			

5.3 Basic Computing Unit

NOTE

A typical basic computing unit in the Tianchi architecture is the basic board.

5.3.1 Introduction to Ports on the Basic Board

Figure 5-3 shows the ports on the basic board.

Figure 5-3 Ports on the basic board

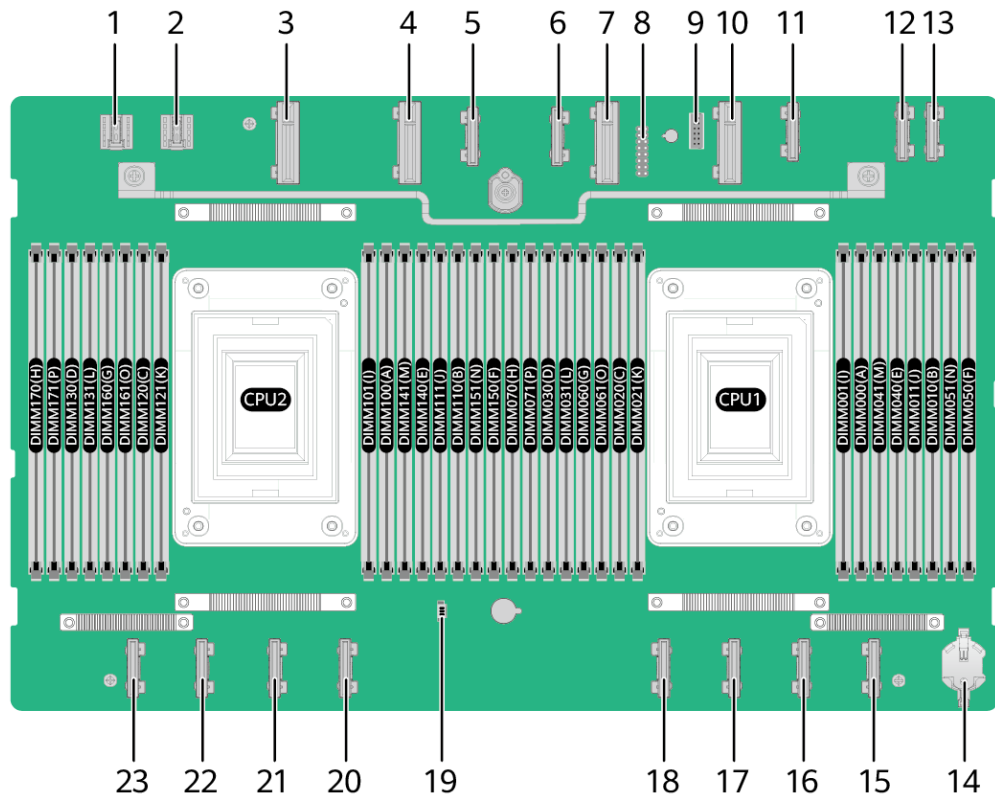

Table 5-3 Ports on basic board 1

No.	Port	No.	Port
1	Power input connector (PWR2/J6073)	2	Power input connector (PWR1/J6074)

No.	Port	No.	Port
3	Northbound UBCDD high-speed connector (CPU2 UBCDD2/J6054)	4	Northbound UBCDD high-speed connector (CPU2 UBCDD1/J6053)
5	Northbound UBC high-speed connector (CPU2 UBC2/J132)	6	Northbound UBC high-speed connector (CPU2 UBC1/J133)
7	Northbound UBCDD high-speed connector (CPU1 UBCDD2/J6052)	8	TPM connector (J50)
9	NC-SI connector (NCSI CONN/J6124)	10	Northbound UBCDD high-speed connector (CPU1 UBCDD1/J6051)
11	Northbound UBC high-speed connector (CPU1 UBC2/J6075)	12	Northbound UBC high-speed connector (CPU1 UBC1/J6076)
13	Sub-5G low-speed UBC connector (MB CONN1/J6077) for interconnection between the basic board and the extension board	14	RTC battery holder (U53)
15	Southbound UBC high-speed connector (CPU1 UBC3/J138)	16	Southbound UBC high-speed connector (CPU1 UBC4/J137)
17	Southbound UBC high-speed connector (CPU1 UBC5/J6057)	18	Southbound UBC high-speed connector (CPU1 UBC6/J6056)
19	Intrusion sensor connector (INTRUDER CONN1/S1)	20	Southbound UBC high-speed connector (CPU2 UBC3/J136)
21	Southbound UBC high-speed connector (CPU2 UBC4/J135)	22	Southbound UBC high-speed connector (CPU2 UBC5/J140)
23	Southbound UBC high-speed connector (CPU2 UBC6/J139)	-	-
Note: The actual connectors may vary.			

 **NOTE**

CPUs are integrated on the basic board and cannot be replaced separately.

5.3.2 Memory

5.3.2.1 DIMM Slot Numbers

A server provides a maximum of 32 DIMM slots. Each processor supports eight memory channels and each memory channel supports two DIMMs.

Figure 5-4 DIMM slot numbers

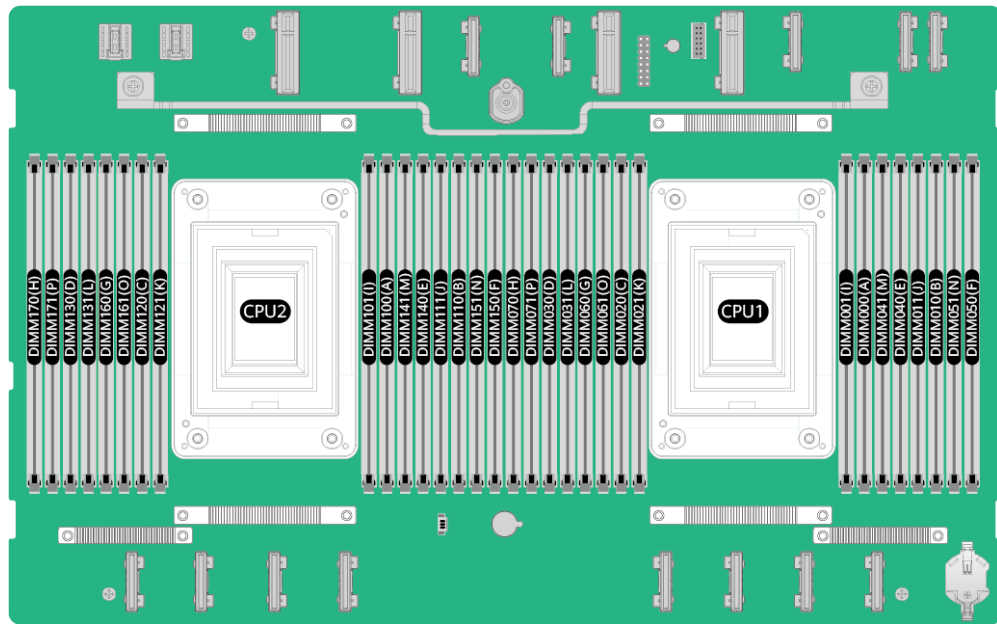

Table 5-4 Composition of channels

CPU	Channel	DIMM
CPU1	TB_A	DIMM020(C)
		DIMM021(K)
	TB_C	DIMM060(G)
		DIMM061(O)
	TB_D	DIMM000(A)
		DIMM001(I)
	TB_F	DIMM040(E)
		DIMM041(M)
	TA_A	DIMM070(H)
		DIMM071(P)
	TA_C	DIMM030(D)
		DIMM031(L)
	TA_D	DIMM050(F)
		DIMM051(N)
	TA_F	DIMM010(B)
		DIMM011(J)

CPU	Channel	DIMM
CPU2	TB_A	DIMM120(C)
		DIMM121(K)
	TB_C	DIMM160(G)
		DIMM161(O)
	TB_D	DIMM100(A)
		DIMM101(I)
	TB_F	DIMM140(E)
		DIMM141(M)
	TA_A	DIMM170(H)
		DIMM171(P)
	TA_C	DIMM130(D)
		DIMM131(L)
	TA_D	DIMM150(F)
		DIMM151(N)
	TA_F	DIMM110(B)
		DIMM111(J)

5.3.2.2 DIMM Installation Rules

NOTICE

- At least one DIMM must be configured in slots supported by CPU 1.
- All the DIMMs on a server must have the same specifications (such as the capacity, bit width, rank, height, and vendor). That is, multiple DIMMs configured on a server must have the same part number (P/N code).

Optimal memory performance can be achieved if each processor in a server is configured with the same number of DIMMs and the DIMMs are evenly distributed among the memory channels. Unbalanced configuration reduces memory performance and is not recommended.

In unbalanced DIMM configuration, DIMMs are not evenly configured for memory channels or processors.

- If a processor is configured with an odd number of DIMMs (such as 3, 5, or 7), the DIMMs are not evenly configured for memory channels.
- If the processors in a server are configured with different number of DIMMs, the DIMMs are not evenly configured for processors.

5.3.2.4 Memory Protection

The server supports the following memory protection technologies:

- Single Device Data Correction (SDDC)
- Memory Demand and Patrol Scrubbing
- Memory Address Parity Protection
- Memory Thermal Throttling
- Data Scrambling
- Error Checking and Correcting (ECC)
- Single-Bit Error Correction, Double-Bit Error Detection (SEC/DED)

5.4 System Extension Unit

NOTE

System extension units in the Tianchi architecture are extension boards.

Figure 5-6 Extension board

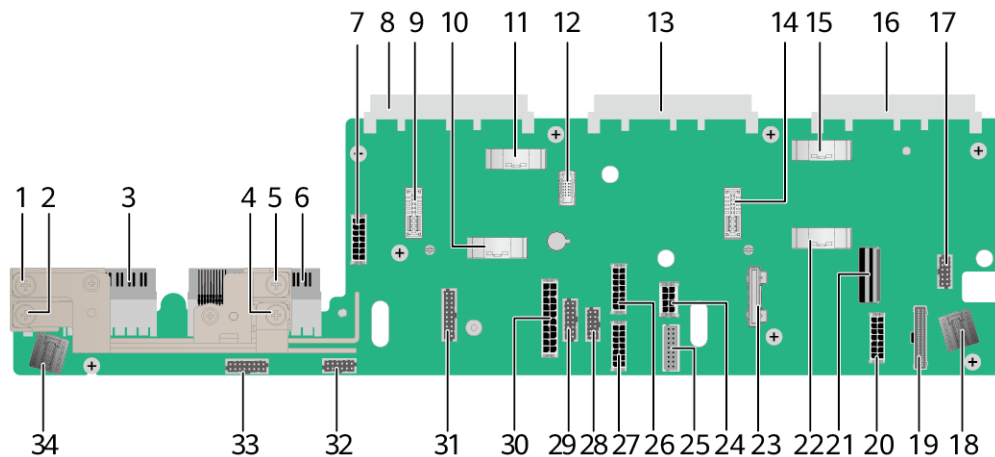

Table 5-6 Port description

No.	Port	No.	Port
1	Basic board power GND	2	Basic board power 12 V
3	PSU 2 connector (J33)	4	Basic board power GND
5	Basic board power 12 V	6	PSU 1 connector (J34)
7	12 V power connector (J12)	8	FlexIO card 2 connector (J27)
9	Riser module 2 power connector (J21)	10	FlexIO card 2 UBC2 connector (higher eight lanes, J40, reserved)

No.	Port	No.	Port
11	FlexIO card 2 UBC1 connector (lower eight lanes, J4)	12	SDI connector (J18)
13	BMC card connector (J43)	14	Riser module 1 power connector (J17)
15	FlexIO card 1 UBC1 connector (J41)	16	FlexIO card 1 connector (J28)
17	Low-speed fan board connector (J5)	18	Fan board power connector (J6)
19	Right mounting ear connector (J26)	20	12 V power connector (J13)
21	M.2/BBU high-speed signal connector (J8)	22	High-speed connector (J42) for interconnection between the extension board and the basic board
23	Low-speed connector (J3) for interconnection between the extension board and the basic board	24	DPU auxiliary power connector (J19)
25	Low-speed M.2 connector (J11)	26	12 V power connector (J15)
27	12 V power connector (J14)	28	NC-SI connector (J31)
29	BBU/Built-in drive backplane low-speed connector (J22)	30	BBU power connector (J10)
31	Left mounting ear connector (J25)	32	Rear drive backplane low-speed connector (J23)
33	Front drive backplane low-speed connector (J7)	34	Front drive backplane power connector (J9)
Note: The actual connectors may vary.			

5.5 Heat Dissipation Components

NOTE

Heat dissipation components in the Tianchi architecture include a fan board and fans.

5.5.1 Fan Board

Figure 5-7 Ports on the fan board

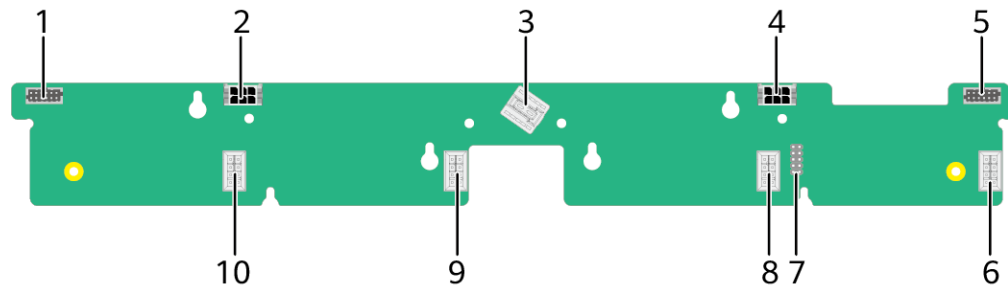

Table 5-7 Port description

No	Port	No	Port
1	Fan board management port connector (FAN CONN/J3)	2	LAAC2 pump connector (reserved, J8)
3	Fan board power connector (FAN PWR/J1)	4	LAAC1 pump connector (reserved, J9)
5	LAAC fan board management connector (reserved, J2)	6	Fan connector 1 (FAN1/J7)
7	JTAG connector (reserved, J602)	8	Fan connector 2 (FAN2/J6)
9	Fan connector 3 (FAN3/J5)	10	Fan connector 4 (FAN4/J4)
Note: The actual connectors may vary.			

5.5.2 Fan Module

The server uses fans that support intelligent speed adjustment. In normal cases, the fans run at the lowest speed. If the server temperature or the air inlet temperature increases, the fans will run faster to enhance heat dissipation.

Figure 5-8 shows the positions of the fans.

Figure 5-8 Fans

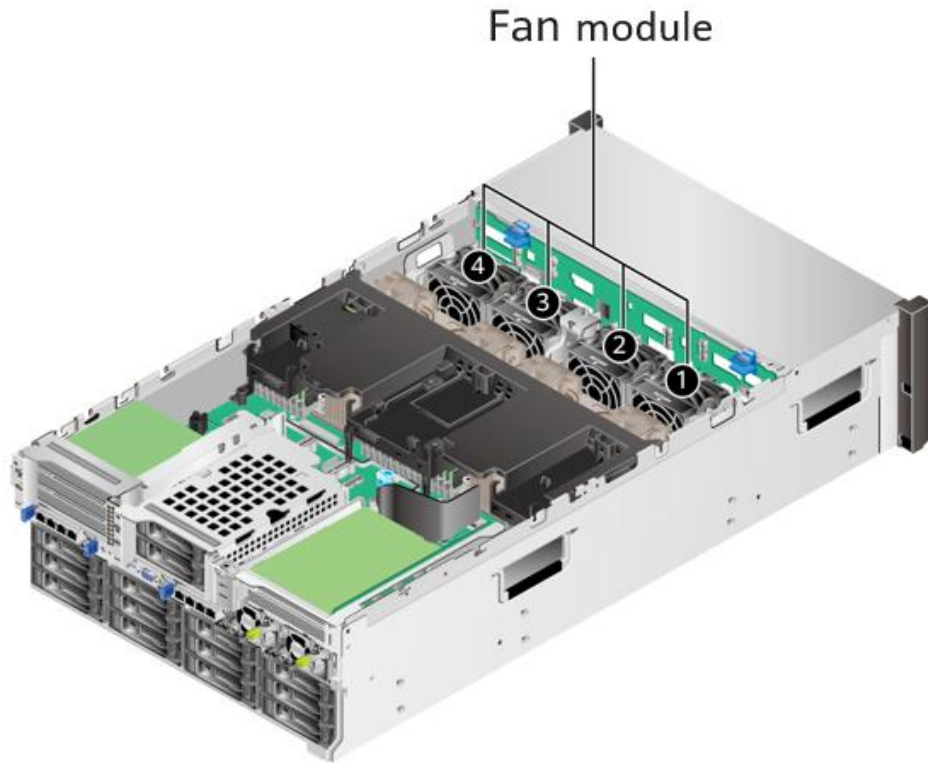

5.6 Storage Components

NOTE

Storage components in the Tianchi architecture are drives.

5.6.1 Drive Configurations

NOTE

The actual configurations are subject to the configuration manual.

Table 5-8 Drive configurations

Configuration	Maximum Front Drives	Maximum Rear Drives	Drive Management Mode
36 x 3.5-inch SAS/SATA drives	24 (SAS/SATA drives)	<ul style="list-style-type: none"> I/O module 2: 2 x 2.5-inch or 2 x 3.5-inch SAS/SATA drives I/O module 3: 4 x 2.5-inch NVMe drives 	One PCIe plug-in RAID controller card ¹

Configuration	Maximum Front Drives	Maximum Rear Drives	Drive Management Mode
		<ul style="list-style-type: none"> Rear: 12 x 3.5-inch SAS/SATA drives 	
1: A PCIe plug-in RAID controller card can be installed in I/O module 1 and is installed in slot 1 by default.			

5.6.2 Drive Numbers

Drive numbers include physical drive numbers, drive numbers displayed on the iBMC WebUI, and drive numbers identified by the RAID controller card. A drive number is used to identify the physical location of a drive.

NOTE

The actual configurations are subject to the configuration manual.

Figure 5-9 shows the drive numbers of a server equipped with 36 x 3.5-inch SAS/SATA drives.

Figure 5-9 Drive numbers of a server equipped with 36 x 3.5-inch SAS/SATA drives



Table 5-9 Drive numbers of a server equipped with 36 x 3.5-inch SAS/SATA drives

Physical Drive Number	Drive Number Identified by the iBMC	Drive Number Identified by a RAID Controller Card
0	Disk0	0
1	Disk1	1
2	Disk2	2
3	Disk3	3
4	Disk4	4
5	Disk5	5
6	Disk6	6
7	Disk7	7
8	Disk8	8
9	Disk9	9
10	Disk10	10
11	Disk11	11
12	Disk12	12
13	Disk13	13
14	Disk14	14
15	Disk15	15
16	Disk16	16
17	Disk17	17
18	Disk18	18
19	Disk19	19
20	Disk20	20
21	Disk21	21
22	Disk22	22
23	Disk23	23
24	Disk24	24
25	Disk25	25
26	Disk26	26
27	Disk27	27
28	Disk28	28

Physical Drive Number	Drive Number Identified by the iBMC	Drive Number Identified by a RAID Controller Card
29	Disk29	29
30	Disk30	30
31	Disk31	31
32	Disk32	32
33	Disk33	33
34	Disk34	34
35	Disk35	35
42	Disk42	36
43	Disk43	37
44	Disk44	-
45	Disk45	-
46	Disk46	-
47	Disk47	-

5.6.3 Drive Indicators

SAS/SATA Drive Indicators

Figure 5-10 SAS/SATA drive indicators

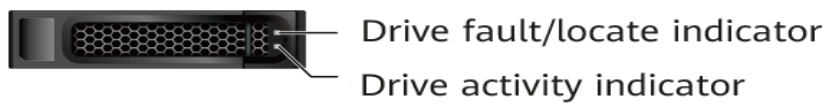

Table 5-10 Drive indicators (SAS/SATA drives)

Drive Activity Indicator (Green)	Drive Fault Indicator (Red)	Drive Locate Indicator (Blue)	Status Description
Off	Off	Off	The drive is not detected.
Steady on	Off	Off	The drive is detected and is working properly.

Drive Activity Indicator (Green)	Drive Fault Indicator (Red)	Drive Locate Indicator (Blue)	Status Description
Blinking at 4 Hz	Off	Off	Data is being read or written properly.
Blinking at 1 Hz	Blinking at 1 Hz	Off	The drive data is being rebuilt.
Steady on	Steady on	Off	The drive is faulty.
Off	Steady on	Off	A member drive in a RAID array is removed.
Steady on	Off	Blinking at 1 Hz	The drive is being located.

NVMe Drive Indicators

Figure 5-11 NVMe drive indicators

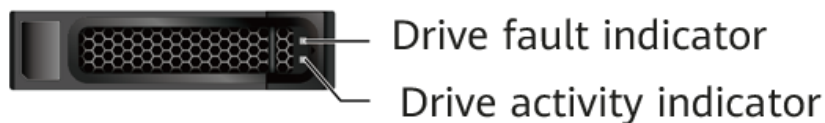

Table 5-11 Drive indicators (NVMe drives)

Drive Activity Indicator (Green)	Drive Fault Indicator (Red)	Drive Locate Indicator (Blue)	Status Description
Off	Off	Off	The drive is not detected or the PCIe link is down.
Steady on	Off	Off	The drive is detected and is working properly.
Blinking	Off	Off	Data is being read from or written to the drive.
-	Off	Blinking at 1 Hz	The drive is being located.
Steady on/off	Blinking at 2 Hz	Off	The drive is being hot-swapped.
Off	Blinking at 0.5 Hz	Off	The hot swap process is completed

Drive Activity Indicator (Green)	Drive Fault Indicator (Red)	Drive Locate Indicator (Blue)	Status Description
			and the drive is removable.
Blinking	Blinking at 1 Hz	Off	The drive data is being rebuilt.
Steady on/off	Steady on	Off	The drive is faulty.

5.6.4 Rear Drive Modules

NOTE

The actual configurations are subject to the configuration manual.

Figure 5-12 and Figure 5-13 show the drive modules supported by I/O module 2. For details, see 5.6.1 Drive Configurations.

Figure 5-12 2 x 3.5-inch rear drive module

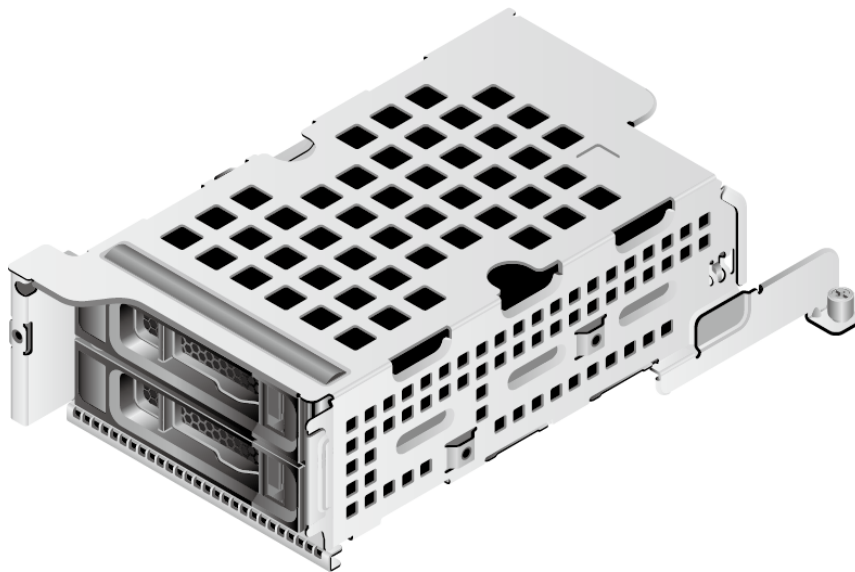
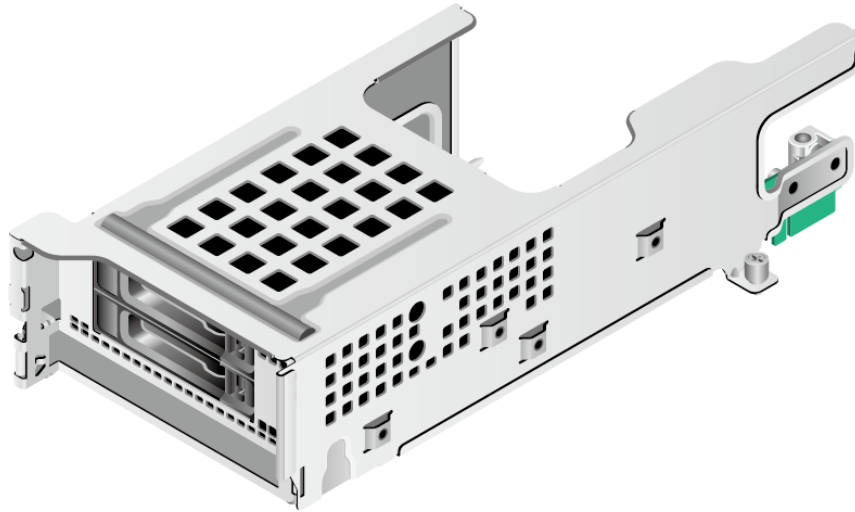
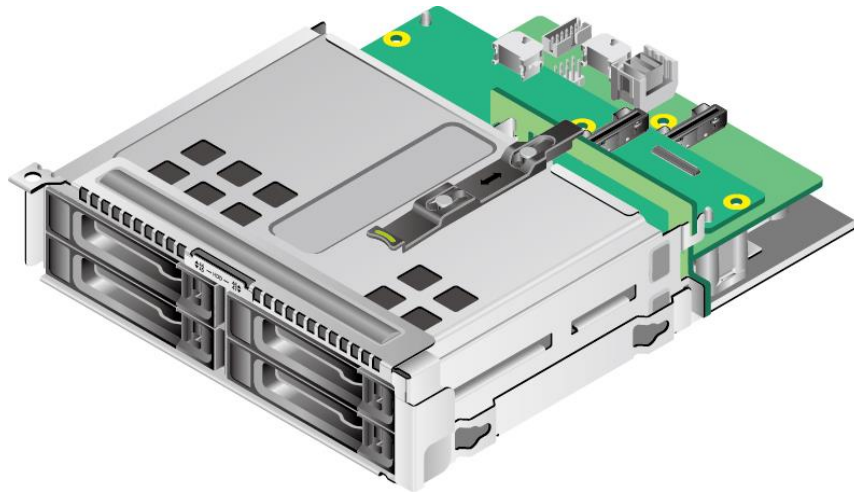

Figure 5-13 2 x 2.5-inch rear drive module



- Figure 5-14 shows the drive module supported by I/O module 3. For details, see 5.6.1 Drive Configurations.

Figure 5-14 4 x 2.5-inch rear drive module



5.6.5 RAID Levels

The performance and drive utilization of RAID groups at different levels are shown in Table 5-12.

Table 5-12 RAID levels

RAID Level	Reliability	Read Performance	Write Performance	Drive Utilization
RAID 0	Low	High	High	100%
RAID 1	High	High	Moderate	50%

RAID Level	Reliability	Read Performance	Write Performance	Drive Utilization
RAID 5	Relatively high	High	Moderate	$(N - 1)/N$
RAID 6	Relatively high	High	Moderate	$(N - 2)/N$
RAID 10	High	High	Moderate	50%
RAID 50	High	High	Relatively high	$(N - M)/N$
RAID 60	High	High	Relatively high	$(N - M \times 2)/N$

Note: N indicates the number of member drives in the RAID array, and M indicates the number of spans in the RAID array.

5.7 Storage Extension Components

NOTE

Storage extension components in the Tianchi architecture are drive backplanes. The actual configurations are subject to the configuration manual.

- Connectors on a backplane of 24 x 3.5-inch drives in pass-through mode

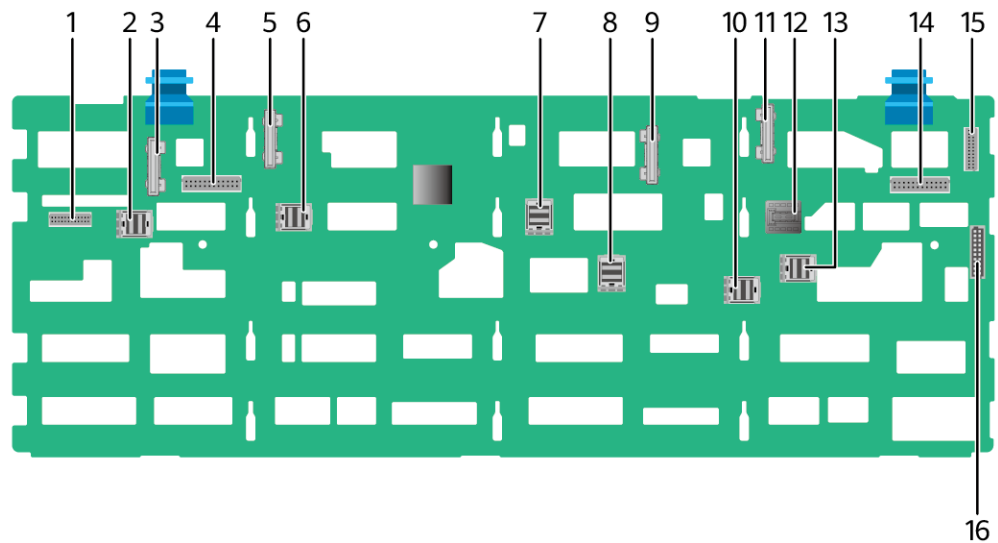

1	Low-speed signal cable connector (J37)	2	Mini-SAS HD connector (J9)
3	UBC connector (J4)	4	Low-speed signal cable connector (J39)
5	UBC connector (J3)	6	Mini-SAS HD connector (J10)
7	Mini-SAS HD connector (J7)	8	Mini-SAS HD connector (J8)
9	UBC connector (J2)	10	Mini-SAS HD connector (J6)
11	UBC connector (J1)	12	Power connector (J41)

13	Mini-SAS HD connector (J5)	14	Low-speed signal cable connector (J40)
15	Low-speed signal cable connector (J36)	16	Low-speed signal cable connector (J38)

- Figure 5-15 shows connectors on a backplane of 12 x 3.5-inch rear drives.

Figure 5-15 Backplane of 12 x 3.5-inch rear drives

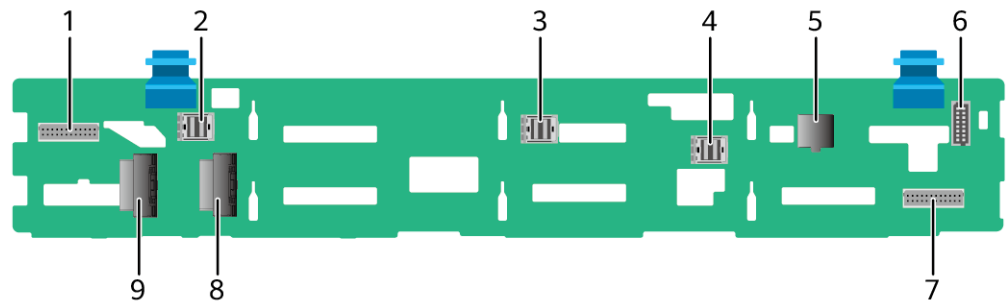

- | | | | |
|---|--|---|--|
| 1 | Low-speed signal cable connector (J17) | 2 | Mini-SAS HD connector (J4) |
| 3 | Mini-SAS HD connector (J3) | 4 | Mini-SAS HD connector (J28) |
| 5 | Power connector (J21) | 6 | Low-speed signal cable connector (J19) |
| 7 | Low-speed signal cable connector (J18) | 8 | UBC connector (J1) |
| 9 | UBC connector (J2) | - | - |

- Figure 5-16 shows connectors on a backplane of 2 x 3.5-inch rear drives.

Figure 5-16 Backplane of 2 x 3.5-inch rear drives

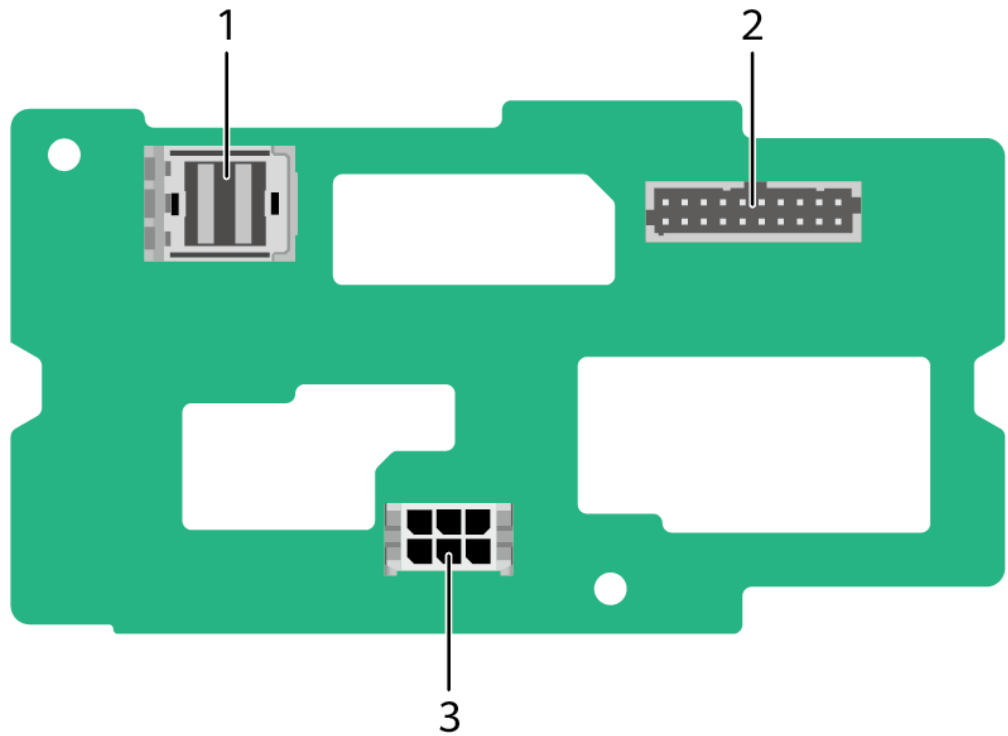

- | | | | |
|---|--------------------------|---|--|
| 1 | Mini-SAS connector (J28) | 2 | Low-speed signal cable connector (J17) |
| 3 | Power connector (J21) | - | - |

- Figure 5-17 shows connectors on a horizontal drive backplane for I/O module 3 (upper board).

Figure 5-17 Horizontal drive backplane for I/O module 3 (upper board)

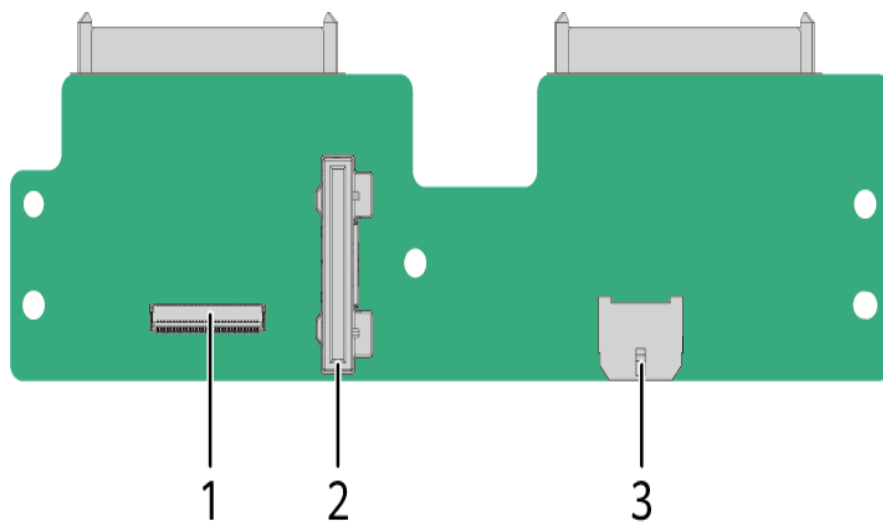

- | | | | |
|---|----------------------|---|--------------------|
| 1 | FPC connector (J702) | 2 | UBC connector (J1) |
|---|----------------------|---|--------------------|

3 Power connector (J1101) - -

- Figure 5-18 shows connectors on a horizontal drive backplane for I/O module 3 (lower board).

Figure 5-18 Horizontal drive backplane for I/O module 3 (lower board)

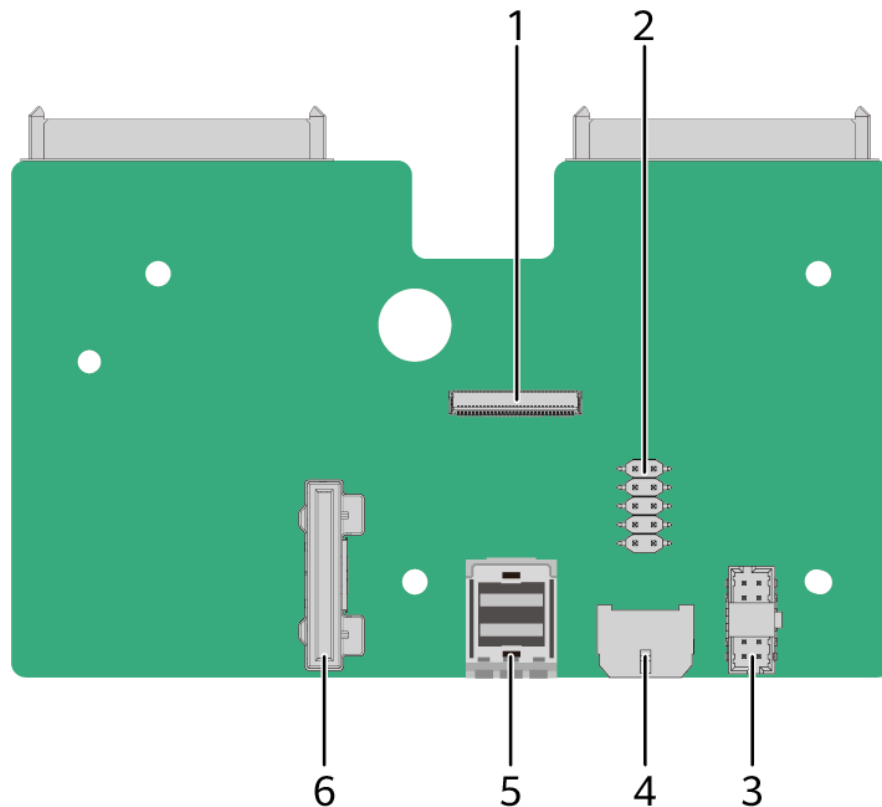

- | | |
|---|---------------------------|
| 1 FPC connector (J702) | 2 JTAG connector (J601) |
| 3 Low-speed signal cable connector (J701) | 4 Power connector (J1101) |
| 5 Mini-SAS connector (J402) | 6 UBC connector (J1) |

5.8 I/O Extension Components

NOTE

Storage extension components in the Tianchi architecture are drive backplanes. The actual configurations are subject to the configuration manual.

Riser Modules Supported By the Server

- Rear riser module with one CEM, one x8, and one x8 slots. See Figure 5-19. The riser module can be installed in I/O modules 1 and 2. For details about the positions of I/O

modules 1 and 2, see 5.2 Rear Panel. If installed in I/O module 1, the riser module uses PCIe slots 1 to 3. If installed in I/O module 2, the riser module uses PCIe slots 4 to 6. The installation depends on the product.

Figure 5-19 Front view of the riser module with one CEM slot, one x8 slot, and one x8 slot

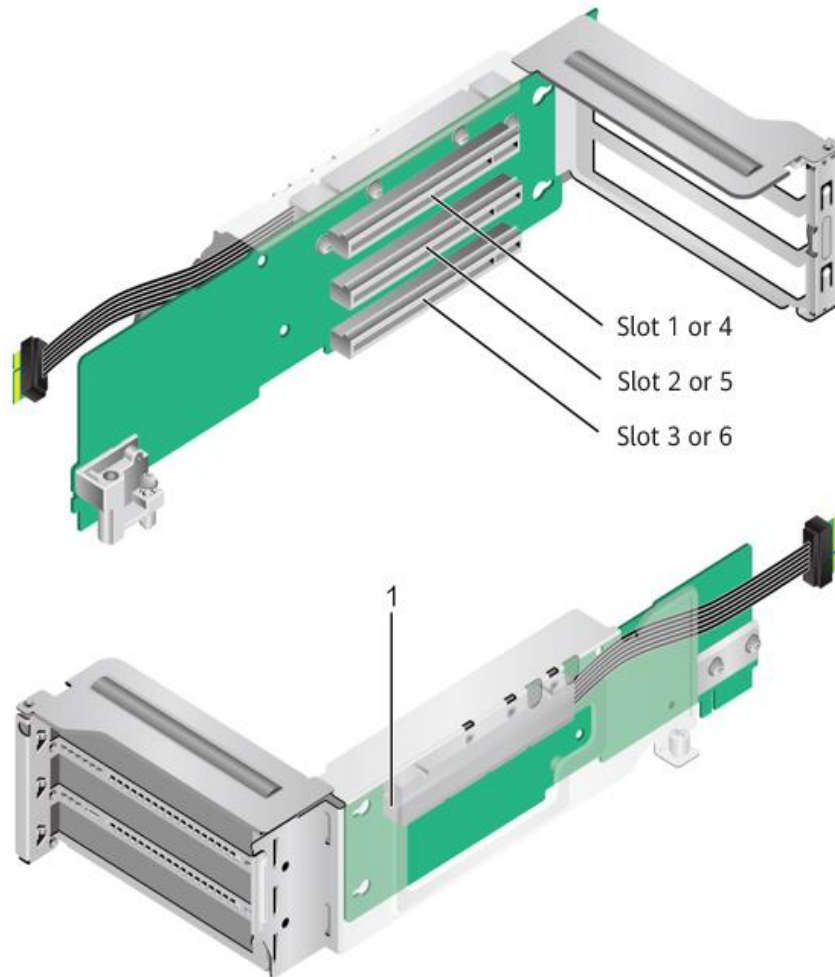

Table 5-13 Connector

No.	Connector
1	CEM cable connector (PCIE SLOT1 X16 5.0 (FH/HL)/J501)

- Rear riser module with three CEM slots. For details, see Figure 5-20 and Figure 5-21. The riser module can be installed in I/O modules 1 and 2. For details about the positions of I/O modules 1 and 2, see 5.2 Rear Panel. If installed in I/O module 1, the riser module uses PCIe slots 1 to 3. If installed in I/O module 2, the riser module uses PCIe slots 4 to 6. The installation depends on the product.

Figure 5-20 Riser module with three CEM slots (1)

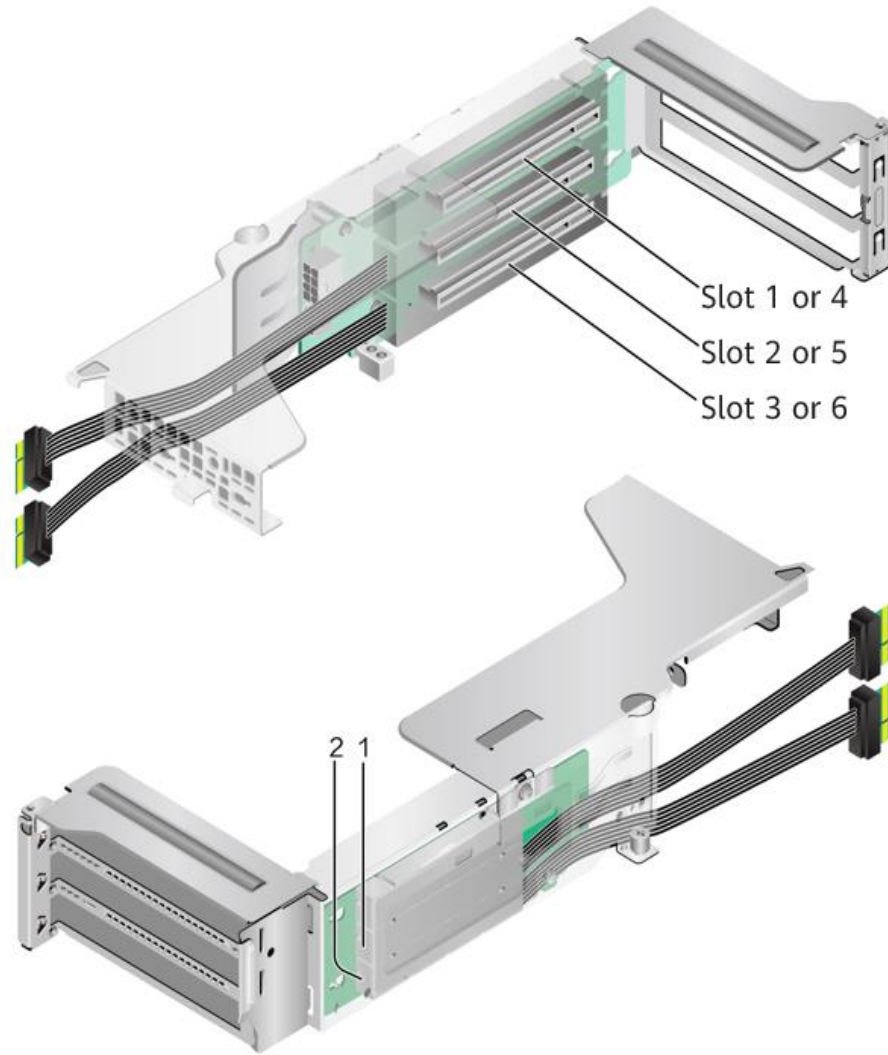

Table 5-14 Connector

No.	Connector	No.	Connector
1	CEM cable connector (PCIE SLOT1 X16 5.0 (FH/FL)/J401)	2	CEM cable connector (PCIE SLOT2 X16 5.0 (FH/FL)/J501)

Figure 5-21 Riser module with three CEM slots (2)

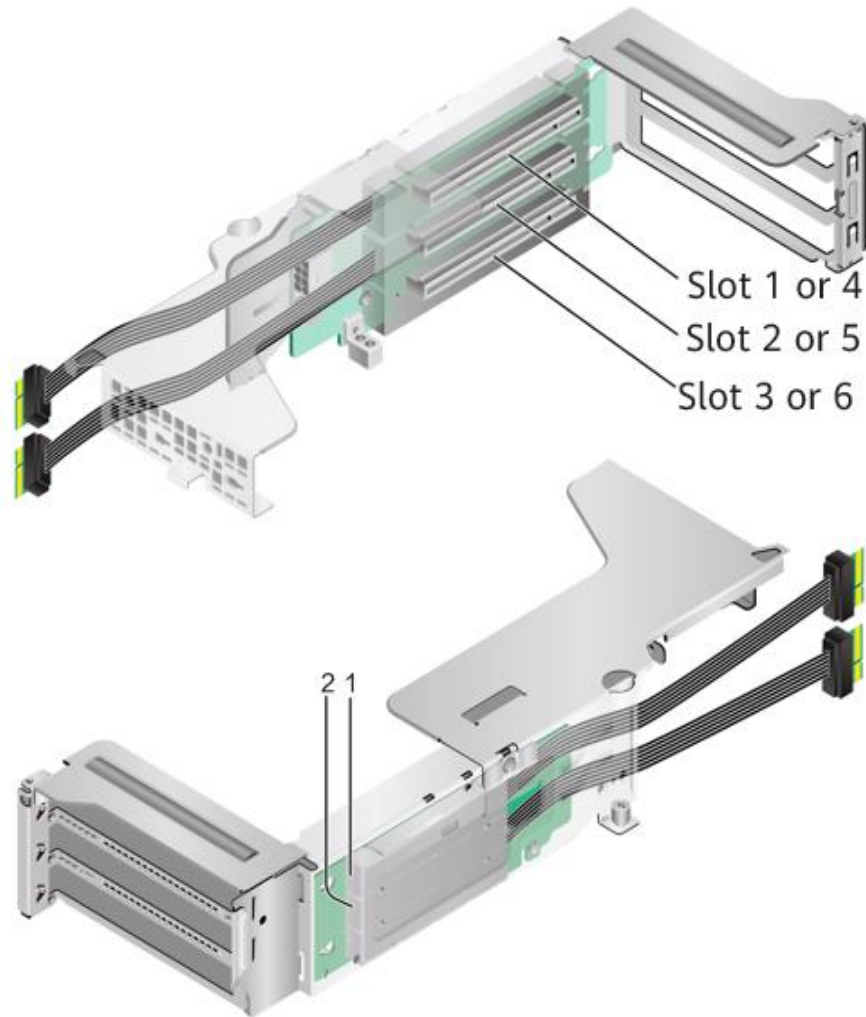
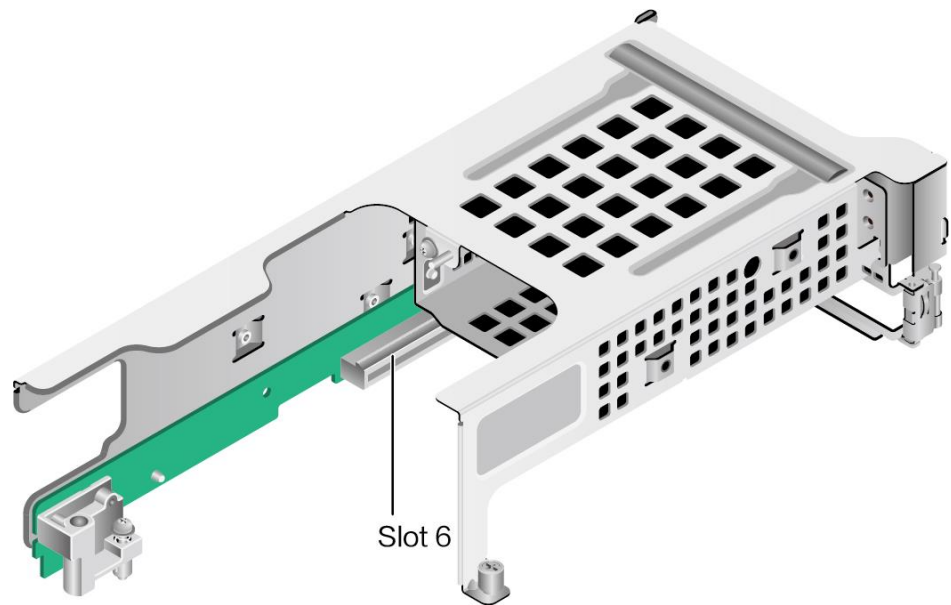

Table 5-15 Connector

No.	Connector	No.	Connector
1	CEM cable connector (PCIE SLOT2 X16 5.0 (FH/FL)/J501)	2	CEM cable connector (PCIE SLOT3 X16 5.0 (FH/HL)/J601)

- Rear riser module with one x16 slot. See Figure 5-22. It can be installed in I/O module 2. When installed in I/O module 2, it provides PCIe slot 6. This module can be configured with 2 x 2.5-inch drives.

Figure 5-22 Riser module with one x16 slot



NOTE

If the server is equipped with an SP686C RAID controller card, the card cannot be installed in slot 6 of the 2 x 2.5-inch rear drive module.

- Rear riser module with one x16 slot. For details, see Figure 5-23 and Figure 5-24. The riser module can be installed in I/O module 3. For details, see 5.2 Rear Panel. The PCIe slot is slot 8.

Figure 5-23 Front view of the riser module with one x16 slot

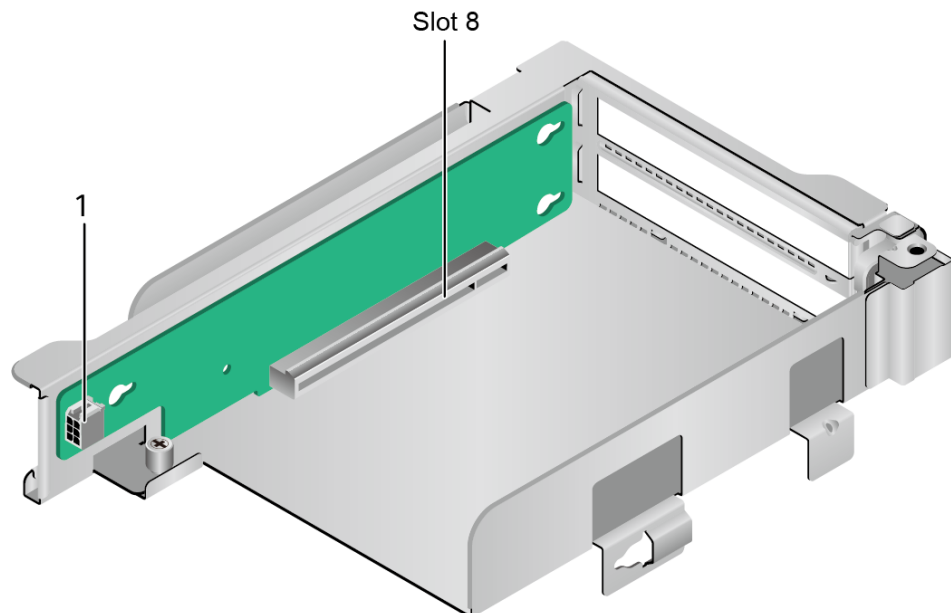

Table 5-16 Connector

No.	Connector
1	Power connector (PWR CONN/J5)

Figure 5-24 Rear view of the riser module with one x16 slot

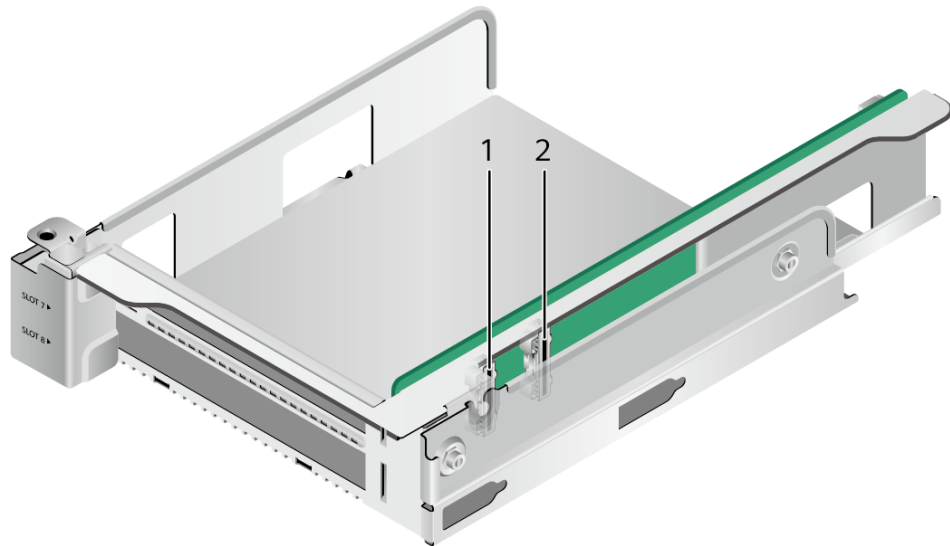

Table 5-17 Connector

No.	Connector	No.	Connector
1	UBC connector (UBC1/J6)	2	UBC connector (UBC2/J7)

- Rear riser module with two x16 slots. For details, see Figure 5-25 and Figure 5-26. The riser module can be installed in I/O module 3. For details, see 5.2 Rear Panel. The PCIe slots are slot 7 and slot 8.

Figure 5-25 Front view of the riser module with two x16 slots

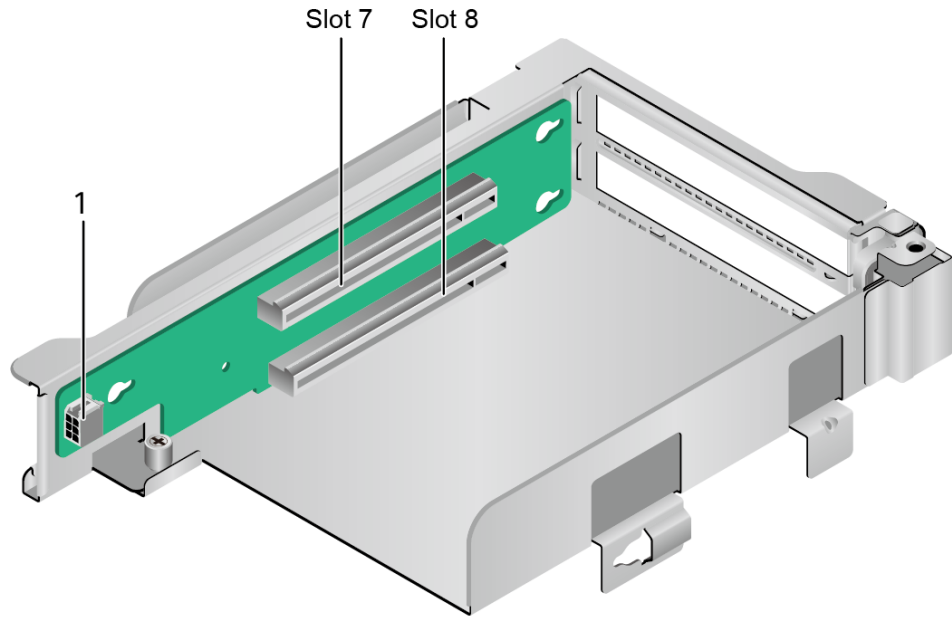

Table 5-18 Connector

No.	Connector
1	Power connector (PWR CONN/J5)

Figure 5-26 Rear view of the riser module with two x16 slots

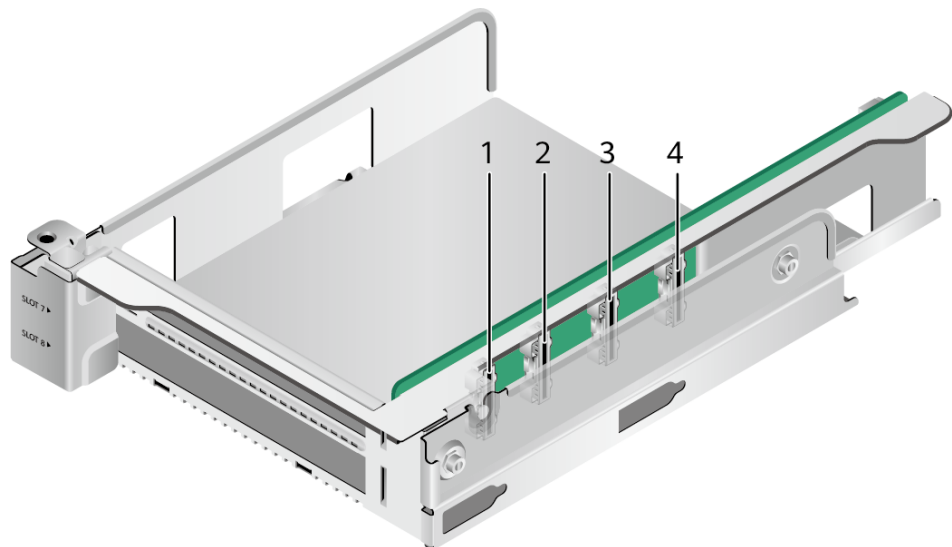

Table 5-19 Connectors

No.	Connector	No.	Connector
1	UBC connector (UBC1/J6)	2	UBC connector (UBC2/J7)
3	UBC connector (UBC3/J1)	4	UBC connector (UBC4/J3)

- Rear riser module with two x8 slots. For details, see Figure 5-27 and Figure 5-28. The riser module can be installed in I/O module 3. For details, see 5.2 Rear Panel. The PCIe slots are slot 7 and slot 8.

Figure 5-27 Front view of the riser module with two x8 slots

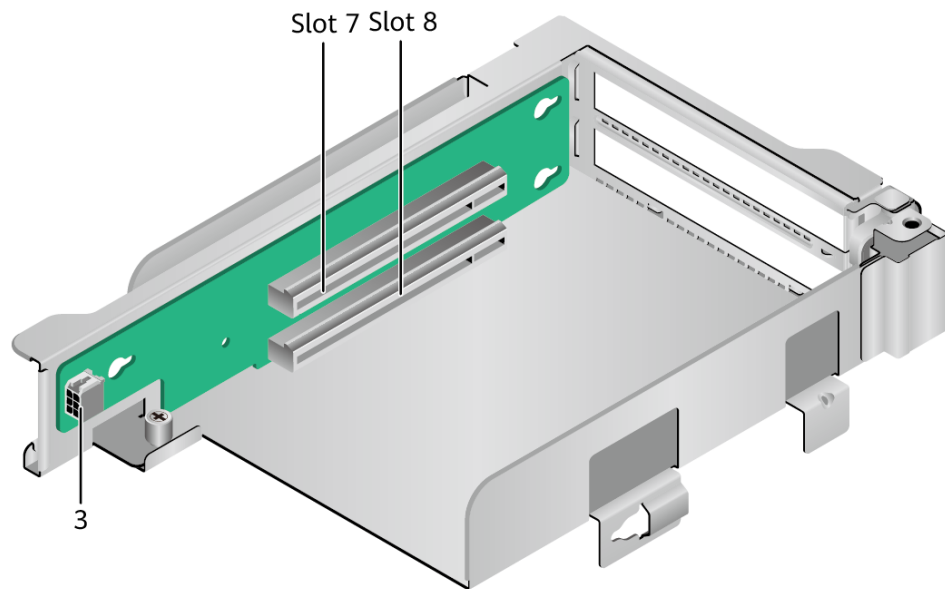

Figure 5-28 Rear view of the riser module with two x8 slots

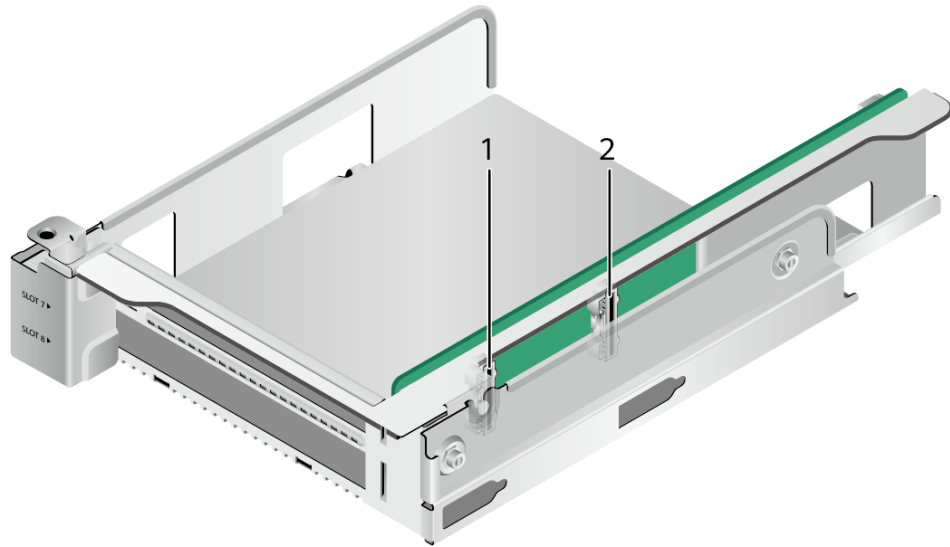

Table 5-20 Connectors

No.	Connector	No.	Connector
1	UBC connector (UBC1/J6)	2	UBC connector (UBC3/J1)
3	Power connector (PWR CONN/J5)	-	-

Layout of Rear PCIe Slots

- Figure 5-29 shows the layout of 8 PCIe slots.

Figure 5-29 8 PCIe slots

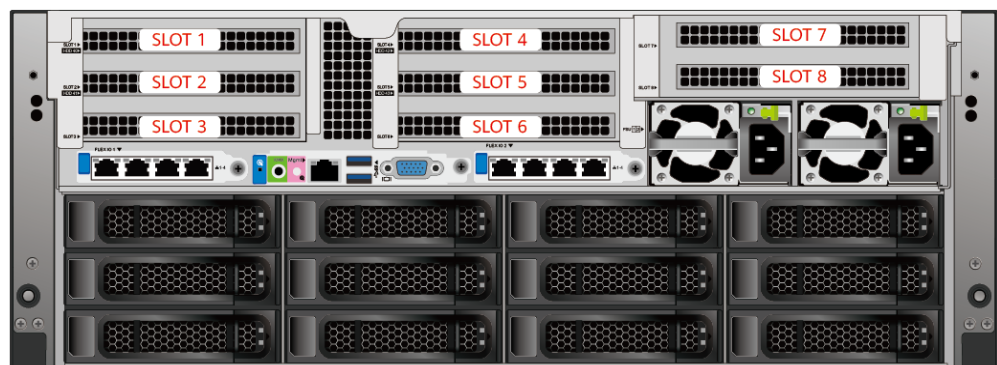

I/O module 1 provides slots 1 to 3, I/O module 2 provides slots 4 to 6, and I/O module 3 provides slots 7 to 8.

PCIe Slot Description

Table 5-21 PCIe slots

PCIe Riser Module	Position of the PCIe Riser Module	PCIe Slot	PCIe Slot Standard	PCIe Slot Width/Bus Width	Port Number in the BIOS	Rot Port (B/D/F)	Device (B/D/F)	CPU Socket	Slot Size
Rear riser module with one CEM, one x8, and one x8 slots	I/O module 1	Slot 1	PCIe 5.0	x16/x16	12	40/00/00	41/00/00	CPU1	Full-height half-length
		Slot 2	PCIe 4.0	x16/x8	10	16/04/00	18/00/0		Full-height half-length
		Slot 3	PCIe 4.0	x16/x8	8	16/00/00	17/00/00		Full-height half-length
	I/O module 2	Slot 4	PCIe 5.0	x16/x16	52	aa/00/00	ab/00/00	CPU2	Full-height half-length
		Slot 5	PCIe 4.0	x16/x8	48	95/00/00	96/00/00		Full-height half-length
		Slot 6	PCIe 4.0	x16/x8	50	95/04/00	97/00/00		Full-height half-length
Rear riser module with three CEM slots	I/O module 1	Slot 1	PCIe 5.0	Configuration 1: x16/x16	12	40/00/00	41/00/00	CPU1	Full-height full-length
				Configuration 2: N/A	-	-	-		
		Slot 2	PCIe 5.0	Configuration 1: x16/x16	8	16/00/00	17/00/00		Full-height full-length
				Configuration 2:	8	16/00/00	17/00/00		

PCIe Riser Module	Position of the PCIe Riser Module	PCIe Slot	PCIe Slot Standard	PCIe Slot Width/Bus Width	Port Number in the BIOS	Rot Port (B/D/F)	Device (B/D/F)	CPU Socket	Slot Size	
		Slot 3	PCIe 5.0	Configuration 1: N/A	-	-	-	CPU2	Full-height half-length	
				Configuration 2: x16/x16	12	40/00/00	41/00/00			
	I/O module 2	Slot 4	PCIe 5.0	Configuration 1: x16/x16	52	aa/00/00	ab/00/00	CPU2	Full-height full-length	
				Configuration 2: N/A	-	-	-			
		Slot 5	PCIe 5.0	Configuration 1: x16/x16	48	95/00/00	96/00/00		Full-height full-length	
				Configuration 2: x16/x16	48	95/00/00	96/00/00			
		Slot 6	PCIe 5.0	Configuration 1: N/A	-	-	-		Full-height half-length	
				Configuration 2: x16/x16	52	aa/00/00	ab/00/00			
	Rear riser module with one x16 slot	I/O module 2	Slot 6	PCIe 4.0	x16/x16	48	95/00/00	96/00/00	CPU2	Full-height half-length
	Rear riser module with one x16 slot	I/O module 3	Slot 8	PCIe 5.0	x16/x16	60	c0/00/00	c1/00/00	CPU2	Full-height half-length
Rear riser module	I/O module 3	Slot 7	PCIe 5.0	x16/x16	72	d5/00/00	d6/00/00	CPU2	Full-height full-length	

PCIe Riser Module	Position of the PCIe Riser Module	PCIe Slot	PCIe Slot Standard	PCIe Slot Width/Bus Width	Port Number in the BIOS	Port (B/D/F)	Device (B/D/F)	CPU Socket	Slot Size
with two x16 slots									ngth
		Slot 8	PCIe 5.0	x16/x16	60	c0/00/00	c1/00/00		Full-height full-length
Rear riser module with two x8 slots	I/O module 3	Slot 7	PCIe 5.0	x16/x8	64	c0/04/00	c2/00/00	CPU2	Full-height full-length
		Slot 8	PCIe 5.0	x16/x8	60	c0/00/00	c1/00/00		Full-height full-length
FlexIO card 1	-	-	-	x8/x8	4	01/04/00	06/00/00	CPU1	-
FlexIO card 2	-	-	-	x8/x8	44	80/04/00	82/00/00	CPU2	-
<p>Note 1: A PCIe slot that supports a full-height full-length (FHFL) PCIe card is backwards compatible with a full-height half-length (FHHL), half-height half-length (HHHL), or half-height full-length (HHFL) PCIe card. A PCIe slot that supports an FHHL PCIe card is backwards compatible with an HHHL PCIe card, and a PCIe slot that supports an HHFL PCIe card is backwards compatible with an HHHL PCIe card.</p> <p>Note 2: A PCIe slot that supports a PCIe x16 card is backwards compatible with a PCIe x8, x4, or x2 card. A PCIe slot that supports a PCIe x8 card is backwards compatible with a PCIe x4 or x2 card.</p> <p>Note 3: All slots support PCIe cards of up to 75 W. The power of a PCIe card depends on its model. For details about the supported PCIe cards, see Compatibility Query. For PCIe cards that are not included in the compatibility list, contact local Huawei sales personnel to submit compatibility test requirements.</p> <p>Note 4: The FlexIO card information in this table applies to PCIe devices (only OCP cards). If NICs are used, refer to the actual bus information.</p>									

5.9 FlexIO Cards

For details about the FlexIO cards supported by the server, see [Compatibility Query](#). For details about FlexIO specifications and features, see the user guide of the FlexIO card you use.

Figure 5-30 SF221Q with four GE electrical ports

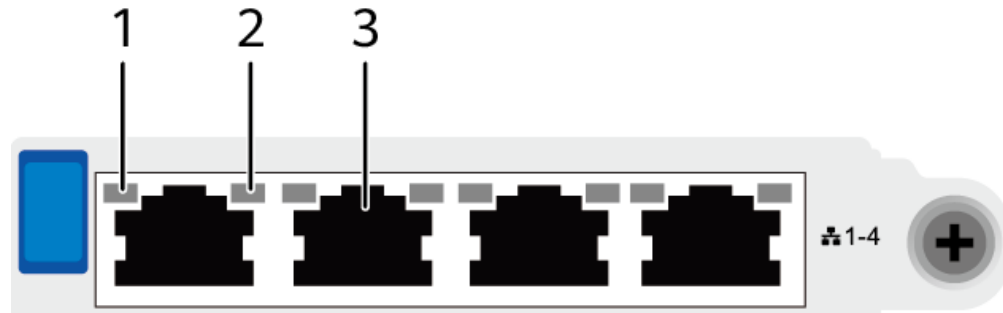

Table 5-22 Ports and indicators on the SF221Q

No.	Port/Indicator	Description
1	Data transmission status indicator	<ul style="list-style-type: none"> Steady yellow: The network port is in active status. Blinking yellow: Data is being transmitted. Off: No data is being transmitted.
2	Connection status indicator	<ul style="list-style-type: none"> Steady green: The network connection is normal. Off: The network is disconnected.
3	GE electrical port	One card provides four GE electrical ports, each functioning as an outbound 1000 Mbit/s Ethernet port that support 10/100/1000 Mbit/s auto-negotiation.

Figure 5-31 SF223D-H (2 x 25GE optical ports)

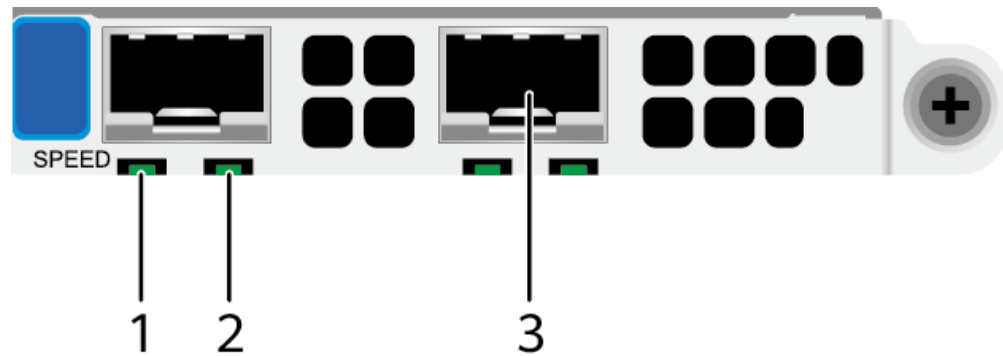

Table 5-23 Ports and indicators on the SF223D-H

No.	Port/Indicator	Description
1	Optical port transmission rate indicator	<ul style="list-style-type: none"> Steady green: The data transmission rate is 25 Gbit/s. Steady yellow: The data transmission rate is 10 Gbit/s. Off: The network is disconnected.
2	Connection status indicator/Data transmission status indicator for the optical port	<ul style="list-style-type: none"> Steady green: The network connection is normal. Blinking green: Data is being transmitted. Off: The network is disconnected.
3	25GE optical port	One card provides two 25GE optical ports that support auto-negotiation to 10GE through optical modules of different rates.

5.10 BMC Card

The product supports the Hi1711 BMC card, which provides VGA, management network, USB, and serial ports. For details, see the VGA, management network, USB, and serial ports in 5.2 Rear Panel.

Figure 5-32 shows the ports on the BMC card.

Figure 5-32 BMC card

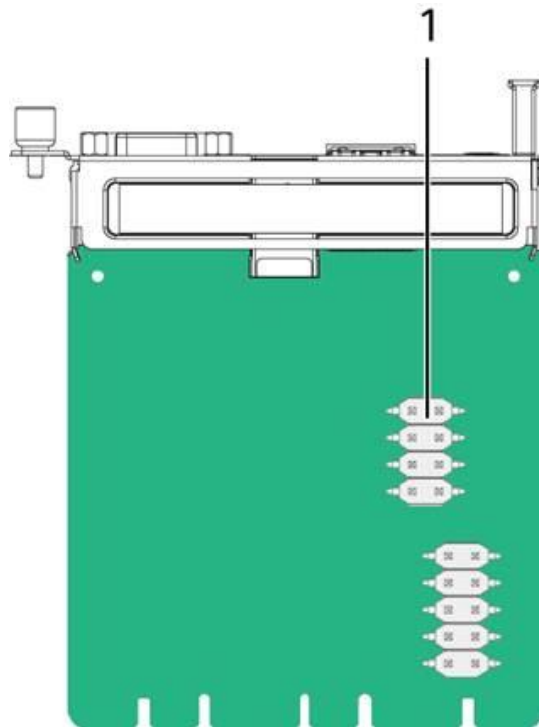

Table 5-24 Port description

No.	Port
1	Jumper

Note 1: You can use a jumper cap to short-circuit the COM_SW pin to change the connection direction of the physical serial port. When the pin is short-circuited, the serial port on the panel is forcibly switched to the BMC serial port. When the pin is disconnected, the source of the serial port is controlled by BMC software and the serial port is automatically switched to the OS serial port after the system is powered on.

Note 2: The actual connectors may vary.

6 Product Specifications

For details about component specifications, see [Compatibility Query](#).

[6.1 Technical Specifications](#)

[6.2 Environmental Specifications](#)

[6.3 Physical Specifications](#)

[6.4 PSU Specifications](#)

6.1 Technical Specifications

NOTE

The actual configurations are subject to the configuration manual.

Table 6-1 Technical specifications

Item	Specifications
Form factor	4U rack server.
Processor	Kunpeng 920: 2 x 24 cores or more.
Memory	<ul style="list-style-type: none">Up to 32 DDR DIMM slots, supporting RDIMMs.Memory rate at 4800 MT/s.32 GB or 64 GB capacity per DIMM.
Storage	<p>SAS/SATA/NVMe drives</p> <ul style="list-style-type: none">For details, see 5.6.1 Drive Configurations.Drives are hot-swappable. <p>RAID controller cards:</p> <ul style="list-style-type: none">For details about supported RAID controller cards, see Compatibility Query.The server supports supercapacitors to protect cache data from power failures, and supports RAID level migration, drive roaming, self-diagnosis, and web-based configuration. For details about the RAID controller cards, see the RAID Controller Card User Guide

Item	Specifications
	(Arm).
FlexIO card	Up to two FlexIO cards per board. A FlexIO card provides the following network ports: <ul style="list-style-type: none"> • Four GE electrical ports, with PXE support. • Two 25GE/10GE optical ports, with PXE support. NOTE Different optical modules can be used for auto-negotiation between 25GE and 10GE.
PCIe slot	Up to 8 PCIe slots. All PCIe slots are standard PCIe slots. The specifications are as follows. <ul style="list-style-type: none"> • I/O module 1 provides the following PCIe slots: <ul style="list-style-type: none"> – One standard full-height half-length PCIe 5.0 x16 slot (width: PCIe 5.0 x16) and two standard full-height half-length PCIe 4.0 x16 slot (width: PCIe 4.0 x8) – Two standard full-height full-length PCIe 5.0 x16 slots (width: PCIe 5.0 x16) or one standard full-height full-length PCIe 5.0 x16 slot (width: PCIe 5.0 x16) and one standard full-height half-length PCIe 5.0 x16 slot (width: PCIe 5.0 x16) • I/O module 2 provides the following PCIe slots: <ul style="list-style-type: none"> – One standard full-height half-length PCIe 5.0 x16 slot (width: PCIe 5.0 x16) and two standard full-height half-length PCIe 4.0 x16 slot (width: PCIe 4.0 x8) – Two standard full-height full-length PCIe 5.0 x16 slots (width: PCIe 5.0 x16) or one standard full-height full-length PCIe 5.0 x16 slot (width: PCIe 5.0 x16) and one standard full-height half-length PCIe 5.0 x16 slot (width: PCIe 5.0 x16) – One standard full-height half-length PCIe 4.0 x16 slot (width: PCIe 4.0 x16). • I/O module 3 provides the following PCIe slots: <ul style="list-style-type: none"> – One standard full-height half-length PCIe 5.0 x16 slot (width: PCIe 5.0 x16) – Two standard full-height full-length PCIe 5.0 x16 slots (width: PCIe 5.0 x16) – Two standard full-height full-length PCIe 5.0 x16 slots (width: PCIe 5.0 x8)
Port	<ul style="list-style-type: none"> • Front panel: two USB 3.0 ports, one DB15 VGA port, and one USB Type-C port. • Rear panel: two USB 3.0 ports, one DB15 VGA port, one 3.5 mm serial port, and one RJ45 management network port.
Fan module	Four hot-swappable fan modules in N+1 (rotor) redundancy NOTE All the fan modules on a server must have the same part number (P/N code).
System management	The iBMC supports Intelligent Platform Management Interface (IPMI), Serial over LAN (SOL), KVM over IP, and virtual media, and provides

Item	Specifications
	one 10/100/1000 Mbit/s RJ45 management network port.
Security	<ul style="list-style-type: none"> Administrator password. Secure boot and trusted boot.
Video card	<p>A video card with 32 MB display memory is integrated on the BMC card. The maximum display resolution is 1920 x 1200 at 60 Hz with 16 M colors.</p> <p>NOTE</p> <ul style="list-style-type: none"> The integrated video card can provide the maximum display resolution (1920 x 1200) only after the video card driver matching the operating system version is installed. Otherwise, only the default resolution supported by the operating system is provided. If both the front and rear VGA ports of a device are connected to a monitor, the front VGA port is used by default.

6.2 Environmental Specifications

Table 6-2 Environmental specifications

Item	Specifications
Temperature	<ul style="list-style-type: none"> Operating temperature: 5°C to 35°C (41°F to 95°F) (ASHRAE Class A1/A2 compliant) Storage temperature (≤ 24 hours): -40°C to +65°C (-40°F to +149°F) Storage temperature (≤ 3 months): -30°C to +60°C (-22°F to +140°F) Storage temperature (≤ 6 months): -15°C to +45°C (5°F to 113°F) Storage temperature (≤ 1 year): -10°C to +35°C (14°F to 95°F) Maximum change rate: 20°C (36°F) per hour, 5°C (9°F) per 15 minutes <p>NOTE The operating temperature range varies depending on the server configuration. For details, see Table 6-3.</p>
Relative humidity (RH, non-condensing)	<ul style="list-style-type: none"> Operating humidity: 8% to 90% Storage humidity (≤ 96 hours): 8% to 95% (40°C) Storage humidity (≤ 3 months): 8% to 85% Storage humidity (≤ 6 months): 8% to 80% Storage humidity (≤ 1 year): 20% to 75% Maximum change rate: 20%/h
Air volume	≥ 155 CFM

Item	Specifications
Altitude	<p>≤ 3050 m (10,006.56 ft)</p> <p>NOTE</p> <ul style="list-style-type: none"> • When the configuration complies with ASHRAE Classes A1 and A2 and the altitude is above 900 m (2952.76 ft), the highest operating temperature decreases by 1°C (1.8°F) for every increase of 300 m (984.25 ft). • When the configuration complies with ASHRAE Class A3 and the altitude is above 900 m (2952.76 ft), the highest operating temperature decreases by 1°C (1.8°F) for every increase of 175 m (574.15 ft). • When the configuration complies with ASHRAE Class A4 and the altitude is above 900 m (2952.76 ft), the highest operating temperature decreases by 1°C (1.8°F) for every increase of 125 m (410.10 ft).
Corrosive airborne contaminant	<p>Maximum growth rate of the corrosion product thickness:</p> <ul style="list-style-type: none"> • Copper corrosion rate test: 300 Å/month (meeting level G1 requirements of the ANSI/ISA-71.04-2013 standard on gaseous corrosion). • Silver corrosion rate test: 200 Å/month.
Particulate matter	<ul style="list-style-type: none"> • The equipment room environment meets the requirements of ISO 14644-1 Class 8. • There is no explosive, conductive, magnetic, or corrosive dust in the equipment room. <p>NOTE</p> <p>It is recommended that the particulate matter in the equipment room be monitored by a professional agency.</p>
Acoustic noise	<p>The declared A-weighted sound power levels (LWAd) and declared average bystander position A-weighted sound pressure levels (LpAm) listed are measured at 23°C (73.4°F) in accordance with ISO 7779 (ECMA 74) and declared in accordance with ISO 9296 (ECMA 109).</p> <ul style="list-style-type: none"> • Idle: <ul style="list-style-type: none"> – LWAd: 6.85 Bels. – LpAm: 51.1 dBA. • Operating: <ul style="list-style-type: none"> – LWAd: 7.15 Bels. – LpAm: 54.2 dBA. <p>NOTE</p> <p>Actual sound levels generated during operation vary depending on the server configuration, load, and ambient temperature.</p>

Table 6-3 Operating temperature limitations

Model	Max. 30°C (86°F)	Max. 35°C (95°F) (ASHRAE Class A2 Compliant)
36 x 3.5-inch SAS/SATA	Rear GPUs are not	Rear GPUs are not

Model	Max. 30°C (86°F)	Max. 35°C (95°F) (ASHRAE Class A2 Compliant)
drives NOTE The CPU power consumption cannot be greater than 325 W.	supported.	supported.
Note 1: When a single fan (rotor) fails, unless otherwise specified, the maximum operating temperature is 5°C (9°F) lower than the normal operating temperature. Note 2: The actual configurations are subject to the configuration manual.		

 **NOTE**

SSDs and HDDs (including NL-SAS, SAS, and SATA) cannot be preserved for a long time in the power-off state. Data may be lost or faults may occur if the preservation time exceeds the specified maximum time. When drives are preserved under the specified storage temperature and humidity, the following preservation time is recommended:

- Maximum preservation time of SSDs:
 - 12 months in power-off state without data stored
 - 3 months in power-off state with data stored
- Maximum preservation time of HDDs:
 - 6 months in unpacked/packed and power-off state
- The maximum preservation time is determined according to the preservation specifications provided by drive vendors. For details, see the manuals provided by drive vendors.

6.3 Physical Specifications

Table 6-4 Physical specifications

Item	Specifications
Dimensions (H x W x D)	175 mm (4U) x 447 mm x 798.5 mm (6.89 in. (4U) x 17.60 in. x 31.44 in.)
Installation space	The server fits into a common cabinet that complies with the IEC 297 standard: <ul style="list-style-type: none"> • Cabinet width: 482.6 mm (19.00 in.) • Cabinet depth: ≥ 1,000 mm (39.37 in.) Requirements for guide rail installation: <ul style="list-style-type: none"> • L-shaped guide rails apply only to Huawei cabinets. • Adjustable guide rails apply to a cabinet with a distance of 543.5 mm to 848.5 mm (21.40 in. to 33.41 in.) between the front and rear mounting bars. • Holding rails apply to a cabinet with a distance of 610 mm to 914 mm (24.02 in. to 35.98 in.) between the front and rear mounting bars.

Item	Specifications
Weight in full configuration	Net weight: 65 kg (143.30 lb). Packaging materials: 5 kg (11.02 lb).
Power consumption	Power consumption specifications vary according to server configurations (including the ErP standard configuration of the European Union). For details, use the Power Calculator .

The following figure shows the chassis.

Figure 6-1 Physical dimensions

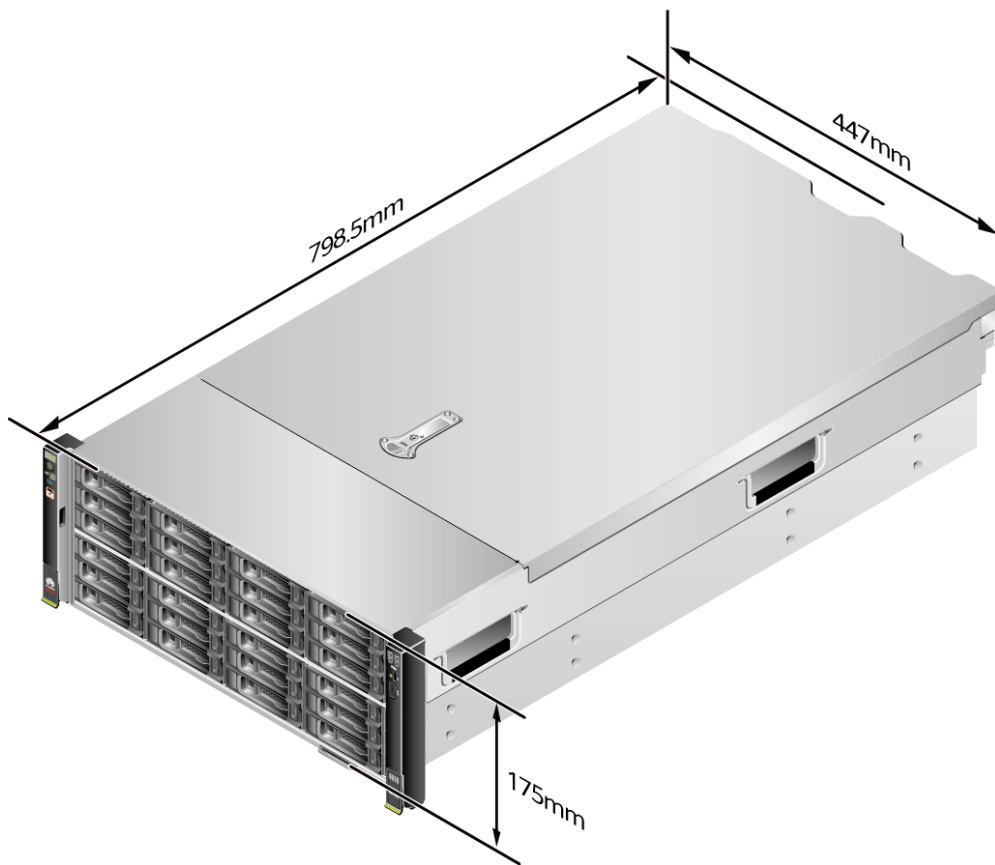

6.4 PSU Specifications

- The PSUs are hot-swappable and work in 1+1 redundancy.

NOTICE

Using a single PSU is not recommended, as it offers no power redundancy.

- For details about supported PSU specifications, use the [Compatibility Query](#).
- The recommended current specifications for an external power circuit breaker connected to the server are as follows:
 - AC power supply: 32 A
- A server must use PSUs of the same model.
- The PSUs provide short-circuit protection. The PSUs that support dual input live wires provide double-pole fuse.
- If the input voltage ranges from 200 V to 220 V AC, the output power of the 2000 W AC Platinum PSUs decreases to 1800 W.

7 Compatibility

[7.1 Hardware and Software Compatibility](#)

[7.2 I/O Extension](#)

7.1 Hardware and Software Compatibility

For details about compatible OSs and hardware, use the [Compatibility Query](#).

NOTICE

The faults caused by use of incompatible components are beyond the scope of technical support and warranty.

7.2 I/O Extension

The server supports a wide variety of PCIe cards. You can select the following PCIe cards based on the card type and rate:

- Ethernet cards
- FC host bus adapters (HBAs)
- InfiniBand (IB) cards
- RAID/HBA cards

NOTE

For details about component options, consult the local Huawei sales representatives.

8 System Management

The iBMC provides rich management functions and features.

- Various management interfaces
The iBMC provides the following standard interfaces to meet various system integration requirements:
 - Data Center Manageability Interface (DCMI) 1.5
 - IPMI 1.5/2.0
 - Command line interface (CLI)
 - Redfish interface
 - Hypertext Transfer Protocol Secure (HTTPS)
 - Simple Network Management Protocol (SNMP)
- Fault monitoring and diagnosis
Faults can be detected and rectified in advance to ensure 24/7 stable running of the device.
 - The iBMC allows breakdown screenshots and video recordings, facilitating cause analysis of the system breakdown.
 - The iBMC offers screen snapshots and videos, simplifying routine preventive maintenance, recording, and auditing.
 - The iBMC supports the reporting of alarms through syslog packets, trap packets, and emails, helping the upper-layer NMS to collect the fault information about the server.
 - Fault Diagnose Management (FDM) provides precise fault diagnosis based on components, facilitating identification and replacement of faulty parts.
- Security management
 - Software image backup improves system security. Even if the running software breaks down, the system can be started from the backup image.
 - Diversified user security control interfaces are provided to ensure user login security.
 - Multiple types of certificates can be imported and replaced to ensure data transmission security.
- System maintenance interfaces
 - The iBMC supports KVM and virtual media to facilitate remote maintenance.

- The iBMC supports RAID out-of-band monitoring and configuration, improving RAID configuration efficiency and management.
- The Smart Provisioning implements OS installation, RAID configuration, and upgrades without a DVD, simplifying server installation and configuration.
- Various network protocols
 - The Network Time Protocol (NTP) synchronizes network time to optimize time configuration.
 - The iBMC supports the domain name system (DNS) and Lightweight Directory Application Protocol (LDAP) to implement domain management and directory service.
- Intelligent power management
 - The power capping technology helps you easily improve deployment density.
 - The iBMC uses dynamic power saving to reduce operational expenditure (OPEX).
- License management

License management allows advanced features to be used by authorized users. The iBMC advanced edition provides the following features:

 - Deploy an OS through the Redfish interface.
 - Enable the Kunpeng Accelerator Engine, which includes the Hardware Security Engine (SEC), High Performance RSA Engine (HPRE), RAID DIF Engine (RDE), and ZIP Engine.

9 Certifications

No.	Country/Region	Certification	Standard
1	China	CCC	GB 4943.1-2022 GB/T 9254.1-2021(Class A) GB 17625.1-2022
2	China	CQC	CQC31-452425-2025 GB 43630-2023
3	China	Air Transport of Goods	IATA DGR:66th, 2025
4	Europe	CE&UKCA	Safety: EN 62368-1:2014+A11:2017 EMC: EN 55032:2015 EN 55032:2015/A11:2020 EN 55035:2017 EN 55035:2017/A11:2020 EN 55024:2010 EN 55024:2010+A1:2015 ETSI EN 300 386 V1.6.1:2012 ETSI EN 300 386 V2.1.1:2016 EN 61000-3-2:2014 EN 61000-3-3:2013 EN 61000-3-3:2013/A1:2019 EN 61000-6-2:2005 EN 61000-6-4:2007+A1:2011 EN IEC 61000-3-2:2019 EN IEC 61000-3-2:2019/A1:2021 RoHS: EN IEC 63000:2018

No.	Country/Region	Certification	Standard
			ErP: Commission Regulation (EU) 2019/424 ETSI EN 303 470 V1.1.1 (2019-03) Generalized Test Protocol for Calculating the Energy Efficiency of Internal Ac-Dc and Dc-Dc Power Supplies Revision 6.7.2
5	North America	NRTL	UL 62368-1:2019 Ed.3 CSA C22.2#62368-1:2019 Ed.3
6	Canada	IC	ICES-003
7	Australia	RCM	EN 55032:2015 EN 55032:2015 / A11:2020 AS/NZS CISPR 32:2015 AS/NZS CISPR 32:2016 AS/NZS CISPR 32:2015/AMD:2019
8	Japan	VCCI	VCCI 32-1
9	-	Commodity inspection	See the product certification.
10	-	CB	IEC 62368-1:2014